



Agilent U7236A 10GBASE-T Electrical Conformance Test Application

Methods of Implementation



Agilent Technologies

Notices

© Agilent Technologies, Inc. 2008

No part of this manual may be reproduced in any form or by any means (including electronic storage and retrieval or translation into a foreign language) without prior agreement and written consent from Agilent Technologies, Inc. as governed by United States and international copyright laws.

Manual Part Number

U7236-97000

Edition

First edition, October 2008

Printed in USA

Agilent Technologies, Inc.
1900 Garden of the Gods Road
Colorado Springs, CO 80907 USA

Warranty

The material contained in this document is provided “as is,” and is subject to being changed, without notice, in future editions. Further, to the maximum extent permitted by applicable law, Agilent disclaims all warranties, either express or implied, with regard to this manual and any information contained herein, including but not limited to the implied warranties of merchantability and fitness for a particular purpose. Agilent shall not be liable for errors or for incidental or consequential damages in connection with the furnishing, use, or performance of this document or of any information contained herein. Should Agilent and the user have a separate written agreement with warranty terms covering the material in this document that conflict with these terms, the warranty terms in the separate agreement shall control.

Technology Licenses

The hardware and/or software described in this document are furnished under a license and may be used or copied only in accordance with the terms of such license.

Restricted Rights Legend

If software is for use in the performance of a U.S. Government prime contract or sub-contract, Software is delivered and licensed as “Commercial computer software” as defined in DFAR 252.227-7014 (June 1995), or as a “commercial item” as defined in FAR 2.101(a) or as “Restricted computer software” as defined in FAR 52.227-19 (June 1987) or any equivalent

agency regulation or contract clause. Use, duplication or disclosure of Software is subject to Agilent Technologies’ standard commercial license terms, and non-DOD Departments and Agencies of the U.S. Government will receive no greater than Restricted Rights as defined in FAR 52.227-19(c)(1-2) (June 1987). U.S. Government users will receive no greater than Limited Rights as defined in FAR 52.227-14 (June 1987) or DFAR 252.227-7015 (b)(2) (November 1995), as applicable in any technical data.

Safety Notices

CAUTION

A **CAUTION** notice denotes a hazard. It calls attention to an operating procedure, practice, or the like that, if not correctly performed or adhered to, could result in damage to the product or loss of important data. Do not proceed beyond a **CAUTION** notice until the indicated conditions are fully understood and met.

WARNING

A **WARNING** notice denotes a hazard. It calls attention to an operating procedure, practice, or the like that, if not correctly performed or adhered to, could result in personal injury or death. Do not proceed beyond a **WARNING** notice until the indicated conditions are fully understood and met.

10GBASE-T Electrical Conformance Test Application — At A Glance

The Agilent U7236A 10GBASE-T Electrical Conformance Test Application helps you verify the transmitter device under test (DUT) conforms to the specifications with the Agilent Infiniium digital storage oscilloscopes. The 10GBASE-T Electrical Conformance Test Application:

- Lets you select individual or multiple tests to run.
- Lets you identify the device being tested and its configuration.
- Shows you how to make oscilloscope, spectrum analyzer and vector network analyzer connections to the device under test.
- Automatically checks for proper oscilloscope configuration.
- Automatically sets up the oscilloscope for each test.
- Provides detailed information for each test that has been run and lets you specify the thresholds at which marginal or critical warnings appear.
- Creates a printable HTML report of the tests that have been run.

NOTE

The tests performed by the 10GBASE-T Electrical Conformance Test Application are intended to provide a quick check of the electrical health of the DUT. This testing is not a replacement for an exhaustive test validation plan.

Compliance testing measurements are described in the *IEEE 802.3-2006 Standard*. For more information, see the IEEE 802 Standards web site at www.ieee802.org.

Required Equipment and Software

In order to run the 10GBASE-T Electrical Conformance Test Application, you need the following equipment and software:

- U7236A 10GBASE-T Electrical Conformance Test Application software.
- 80000 or 90000 Series Infiniium Digital Storage Oscilloscope (DSO). Agilent recommends using 2 GHz and higher bandwidth oscilloscope.
- Version 5.50 or greater of Infiniium software (80000 Series oscilloscope)
OR
- Version 1.21 or greater of baseline software (90000 Series oscilloscope).
- Agilent also recommends using a second monitor to view the automated test application.
- Spectrum Analyzer with the minimum frequency range upper limit of 3 GHz (MXA, EXA, PSA or ESA series).
- Vector Network Analyzer with usable frequency range of 1 MHz to 500 MHz (875x, 439x, E506x/7x and N5230A series).
- Balun with 3 GHz bandwidth.

- U7237A 10GBASE-T Transmitter test fixture.
- SMA cable (24" or shorter).
- SMP to SMA cables (provided with U7237A 10GBASE-T Transmitter test fixture).
- Keyboard, quantity = 1 (provided with Agilent Infiniium oscilloscope).
- Mouse, quantity = 1 (provided with Agilent Infiniium oscilloscope).

Below is the required license:

- U7236A 10GBASE-T Electrical Conformance Test Application license.
- Memory Upgrade Option 001 is recommended for the 80000 Series oscilloscopes for best performance.

In This Book

This manual describes the tests that are performed by the 10GBASE-T Electrical Conformance Test Application in more detail; it contains information from (and refers to) the *IEEE 802.3-2006 Standard* and it describes how the tests are performed.

- [Chapter 1](#), “Installing the 10GBASE-T Electrical Conformance Test Application” shows how to install and license the automated test application software (if it was purchased separately).
- [Chapter 2](#), “Preparing to Take Measurements” shows how to start the 10GBASE-T Electrical Conformance Test Application and gives a brief overview of the required preparation and how the application is used.
- [Chapter 3](#), “U7237A 10GBASE-T Transmitter Test Fixtures” describes the U7237A 10GBASE-T transmitter test fixture in detail.
- [Chapter 4](#), “Transmitter Timing Jitter (MASTER) Test” contains information on the transmitter timing jitter MASTER test as specified in clause 55.5.3.3 of the *IEEE 802.3-2006 Standard*.
- [Chapter 5](#), “Transmit Clock Frequency Test” contains information on the transmit clock frequency test as specified in clause 55.5.3.5 of the *IEEE 802.3-2006 Standard*.
- [Chapter 6](#), “Maximum Output Droop Test” contains information on the positive and negative droop test as specified in clause 55.5.3.1 of the *IEEE 802.3-2006 Standard*.
- [Chapter 7](#), “Transmitter Power Spectral Density Test” contains information on the power spectral density test as specified in clause 55.5.3.4 of the *IEEE 802.3-2006 Standard*.
- [Chapter 8](#), “Power Level Test” contains information on the power level test as specified in clause 55.5.3.4 of the *IEEE 802.3-2006 Standard*.
- [Chapter 9](#), “Transmitter Linearity Tests” contains information on the transmitter linearity tests as specified in clause 55.5.3.2 of the *IEEE 802.3-2006 Standard*.
- [Chapter 10](#), “MDI Return Loss Test” contains information on the MDI return loss test as specified in clause 55.8.2.1 of the *IEEE 802.3-2006 Standard*.
- [Chapter 11](#), “Transmitter Timing Jitter (SLAVE) Test” contains information on the transmitter timing jitter SLAVE test as specified in clause 55.5.3.3 of the *IEEE 802.3-2006 Standard*.
- [Appendix I](#), “Calibrating the 80000 and 90000 Series Infiniium Oscilloscopes” describes how to calibrate the oscilloscope in preparation for running the 10GBASE-T automated tests.

See Also

- The 10GBASE-T Electrical Conformance Test Application’s online help, which describes:

- Creating or opening a test project.
- Setting up tests.
- Selecting tests.
- Configuring selected tests.
- Connecting the oscilloscope to the DUT.
- Running tests.
- Viewing test results.
- Viewing/printing the HTML test report.
- Saving test projects.

Contents

10GBASE-T Electrical Conformance Test Application — At A Glance	3
Required Equipment and Software	3
In This Book	5
See Also	5
1 Installing the 10GBASE-T Electrical Conformance Test Application	
Installing the Software	11
Installing the License Key	11
2 Preparing to Take Measurements	
Calibrating the Oscilloscope	14
Starting the 10GBASE-T Electrical Conformance Test Application	15
Online Help Topics	17
3 U7237A 10GBASE-T Transmitter Test Fixtures	
U7237A 10GBASE-T Transmitter Test Fixture Description	20
Fixture and Accessories	22
Dimension	22
Test Modes	23
Characteristics, Regulatory, and Safety Information	24
Electrical Characteristics	24
Operating and Non-operating Environmental Characteristics	24
Safety Information	25
4 Transmitter Timing Jitter (MASTER) Test	
Connection for Transmitter Timing Jitter (MASTER) Test	28
Test Procedure	28
Transmitter Timing Jitter (MASTER) Test - Test Method of Implementation	31
Test Definition Notes from the Specification	31
Pass Condition	31
Measurement Algorithm	31
Test References	32

5 Transmit Clock Frequency Test

Connection for Transmit Clock Frequency Test	34
Test Procedure	34
Transmit Clock Frequency Test - Test Method of Implementation	36
Test Definition Notes from the Specification	36
Pass Condition	36
Measurement Algorithm	36
Test References	36

6 Maximum Output Droop Test

Connection for Maximum Output Droop Test	38
Test Procedure	38
Maximum Output Droop Test - Test Method of Implementation	40
Test Definition Notes from the Specification	40
Pass Condition	40
Measurement Algorithm	40
Test References	41
	42

7 Transmitter Power Spectral Density Test

Connection for Transmitter Power Spectral Density Test	44
Test Procedure	44
Transmitter Power Spectral Density Test - Test Method of Implementation	50
Test Definition Notes from the Specification	50
Pass Condition	51
Measurement Algorithm	51
Test References	52

8 Power Level Test

Connection for Power Level Test	54
Test Procedure	54
Power Level Test - Test Method of Implementation	60
Test Definition Notes from the Specification	60
Pass Condition	60
Measurement Algorithm	61
Test References	61

9 Transmitter Linearity Tests

Connection for Transmitter Linearity Tests	64
Test Procedure	64
Transmitter Linearity Tests - Test Method of Implementation	70
Test Definition Notes from the Specification	70
Pass Condition	70
Measurement Algorithm	71
Test References	72

10 MDI Return Loss Test

Connection for MDI Return Loss Test	74
Test Procedure	74
MDI Return Loss Test - Test Method of Implementation	82
Test Definition Notes from the Specification	82
Pass Condition	82
Measurement Algorithm	82
Test References	83

11 Transmitter Timing Jitter (SLAVE) Test

Connection for Transmitter Timing Jitter (SLAVE) Test	86
Test Procedure	87
Transmitter Timing Jitter (SLAVE) Test - Test Method of Implementation	89
Test Definition Notes from the Specification	89
Pass Condition	89
Measurement Algorithm	89
Test References	90

I Calibrating the 80000 and 90000 Series Infiniium Oscilloscopes

To Run the Self Calibration	91
Self Calibration	92

Index

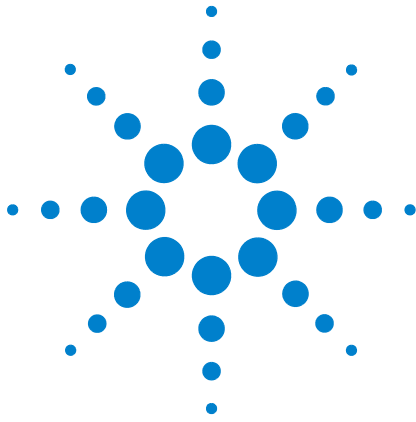

1 Installing the 10GBASE-T Electrical Conformance Test Application

Installing the Software 11
Installing the License Key 11

If you purchased the U7236A 10GBASE-T Electrical Conformance Test Application separately, you need to install the software and license key.

Installing the Software

- 1 Make sure you have version 5.50 or higher of the Infiniium oscilloscope software (80000 Series oscilloscope) OR version 1.21 or greater of baseline software (90000 Series oscilloscope) by choosing **Help>About Infiniium...** from the main menu.
- 2 To obtain the 10GBASE-T Electrical Conformance Test Application, go to Agilent website: <http://www.agilent.com/find/scope-apps-sw>.

The link for 10GBASE-T Electrical Conformance Test Application will appear. Double-click on it and follow the instructions to download and install the application software.

Installing the License Key

- 1 Request a license code from Agilent by following the instructions on the Entitlement Certificate.

You will need the oscilloscope's "Option ID Number", which you can find in the **Help>About Infiniium...** dialog.

- 2 After you receive your license code from Agilent, choose **Utilities>Install Option License....**
- 3 In the Install Option License dialog, enter your license code and click **Install License**.
- 4 Click **OK** in the dialog that tells you to restart the Infiniium oscilloscope application software to complete the license installation.
- 5 Click **Close** to close the Install Option License dialog.

1 Installing the 10GBASE-T Electrical Conformance Test Application

- 6 Choose **File>Exit**.
- 7 Restart the Infiniium oscilloscope application software to complete the license installation.

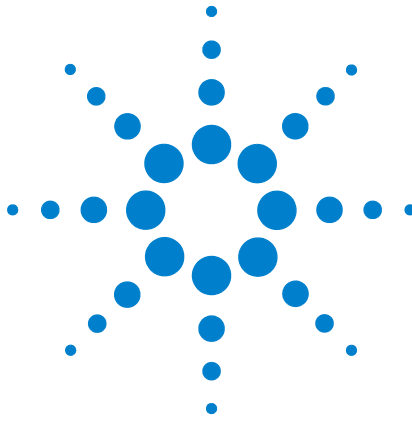

2 Preparing to Take Measurements

Calibrating the Oscilloscope 14

Starting the 10GBASE-T Electrical Conformance Test Application 15

Before running the 10GBASE-T Electrical Conformance Test Application automated tests, you should calibrate the oscilloscope. Once the oscilloscope has been calibrated, you are ready to start the 10GBASE-T Electrical Conformance Test Application and perform the measurements.

Calibrating the Oscilloscope

If you haven't already calibrated the oscilloscope, see [Appendix I](#), "Calibrating the 80000 and 90000 Series Infiniium Oscilloscopes".

NOTE

If the ambient temperature changes more than 5 degrees Celsius from the calibration temperature, internal calibration should be performed again. The delta between the calibration temperature and the present operating temperature is shown in the Utilities>Calibration menu.

NOTE

If you switch cables or probes between channels or other oscilloscopes, it is necessary to perform cable and probe calibration again. Agilent recommends that, once calibration is performed, you label the cables with the channel for which they were calibrated.

Starting the 10GBASE-T Electrical Conformance Test Application

- 1 From the Infiniium oscilloscope’s main menu, choose Analyze>Automated Test Apps>10GBase-T Ethernet Test.

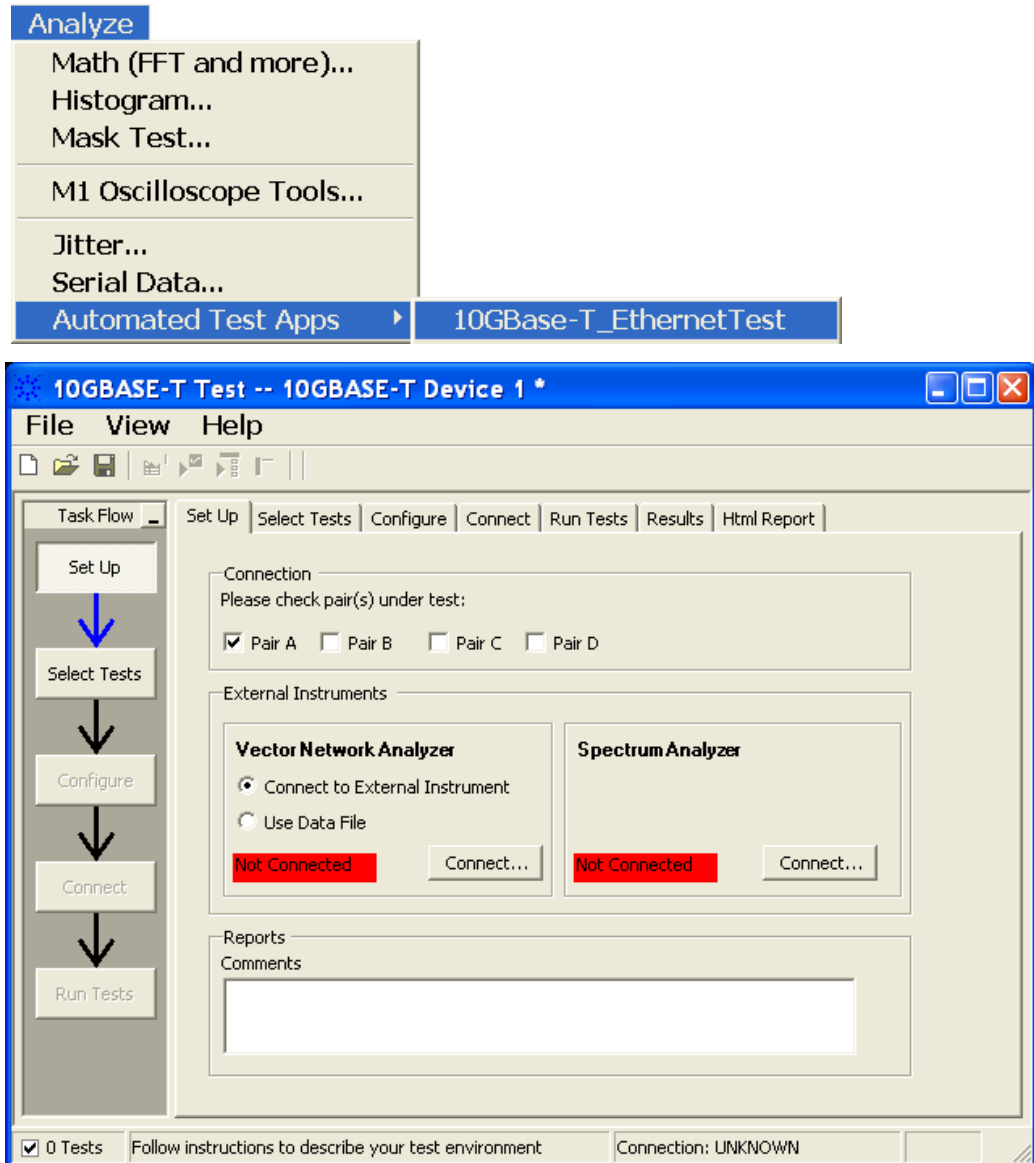

Figure 1 The 10GBASE-T Electrical Conformance Test Application

NOTE

If 10GBASE-T Ethernet does not appear in the Automated Test Apps menu, the 10GBASE-T Electrical Conformance Test Application has not been installed (see Chapter 1, “Installing the 10GBASE-T Electrical Conformance Test Application”).

Figure 1 shows the 10GBASE-T Electrical Conformance Test Application main window. The task flow pane, and the tabs in the main pane, show the steps you take in running the automated tests:

Set Up	Lets you identify the test environment, including information about the device being tested and other test instruments that can be automatically configured.
Select Tests	Lets you select the tests you want to run. The tests are organized hierarchically so you can select all tests in a group. After tests are run, status indicators show which tests have passed, failed, or not been run, and there are indicators for the test groups.
Configure	Lets you configure test parameters.
Connect	Shows you how to connect the oscilloscope, spectrum analyzer and vector network analyzer to the device under test for the tests to be run.
Run Tests	Starts the automated tests. If the connections to the device under test need to be changed while multiple tests are running, the tests pause, show you how to change the connection, and wait for you to confirm that the connections have been changed before continuing.
Results	Contains more detailed information about the tests that have been run. You can change the thresholds at which marginal or critical warnings appear.
HTML Report	Shows a compliance test report that can be printed.

Online Help Topics

For information on using the 10GBASE-T Electrical Conformance Test Application, see its online help (which you can access by choosing Help>Contents... from the application's main menu).

The 10GBASE-T Electrical Conformance Test Application's online help describes:

- Starting the 10GBASE-T Electrical Conformance Test Application
 - To view/minimize the task flow pane
 - To view/hide the toolbar
- Creating or opening a test project.
- Setting up tests and equipment.
- Selecting tests.
- Configuring selected tests.
- Connecting the oscilloscope to the DUT.
- Running tests.
- Viewing test results.
 - To show reference images and flash mask hits.
 - To change the display settings.
 - To change the remote settings.
 - To change margin thresholds and report trial display.
 - To change the loading and auto-recovery option.
- Viewing/Exporting/Printing the HTML test report.
- Saving test projects.

2 Preparing to Take Measurements

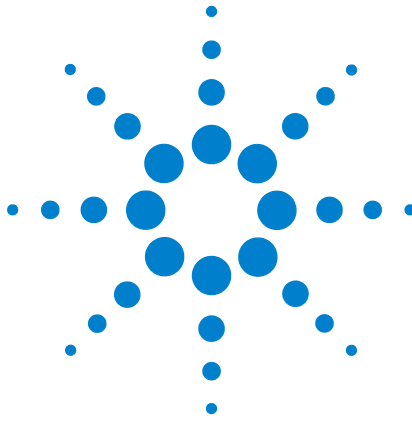

3

U7237A 10GBASE-T Transmitter Test Fixtures

U7237A 10GBASE-T Transmitter Test Fixture Description	20
Test Modes	23
Characteristics, Regulatory, and Safety Information	24

The U7237A 10GBASE-T transmitter test fixtures are required to perform the 10GBASE-T electrical conformance test measurements.

U7237A 10GBASE-T Transmitter Test Fixture Description

The U7237A 10GBASE-T transmitter test fixture is required to perform the measurement with the 10GBASE-T Electrical Conformance Test Application. The fixture helps you to easily access the 10GBASE-T test signals.

The fixture has 3 sections: Section 1, Section 2 and Section 3.

Section 1 of the U7237A 10GBASE-T transmitter test fixture is required for the following tests:

- Transmitter timing jitter (MASTER) test
- Transmit clock frequency test
- Maximum output droop test
- Transmitter power spectral density test
- Power level test
- Transmitter linearity tests
- MDI return loss test

Section 2 of the fixture is required for the following test:

- Transmitter timing jitter (SLAVE) test

Section 3 of the fixture is required for calibration during the MDI return loss test.

Figure 2, Figure 3 and Figure 4 shows the U7237A 10GBASE-T transmitter test fixtures. The U7237A 10GBASE-T transmitter test fixture is shipped to you as one piece of board with 3 sections, as shown in Figure 2. The board has a V-cut break-out tab that allows you to easily separate the board into two pieces.

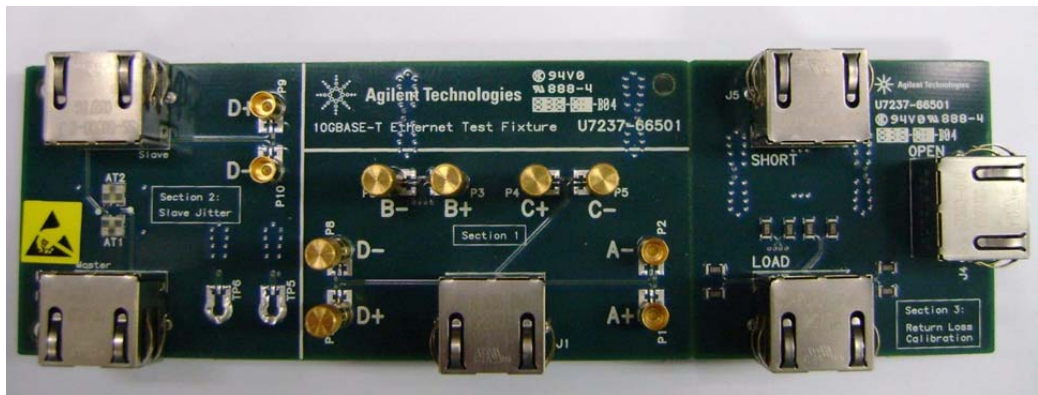

Figure 2 Complete U7237A 10GBASE-T Transmitter Test Fixture Board

The bigger piece of board, as shown in Figure 3 has Section 1 and Section 2. This sections are required to perform the conformance tests. Whereas, the smaller board which has Section 3, as shown in Figure 4 is required to calibrate the Vector Network Analyzer.

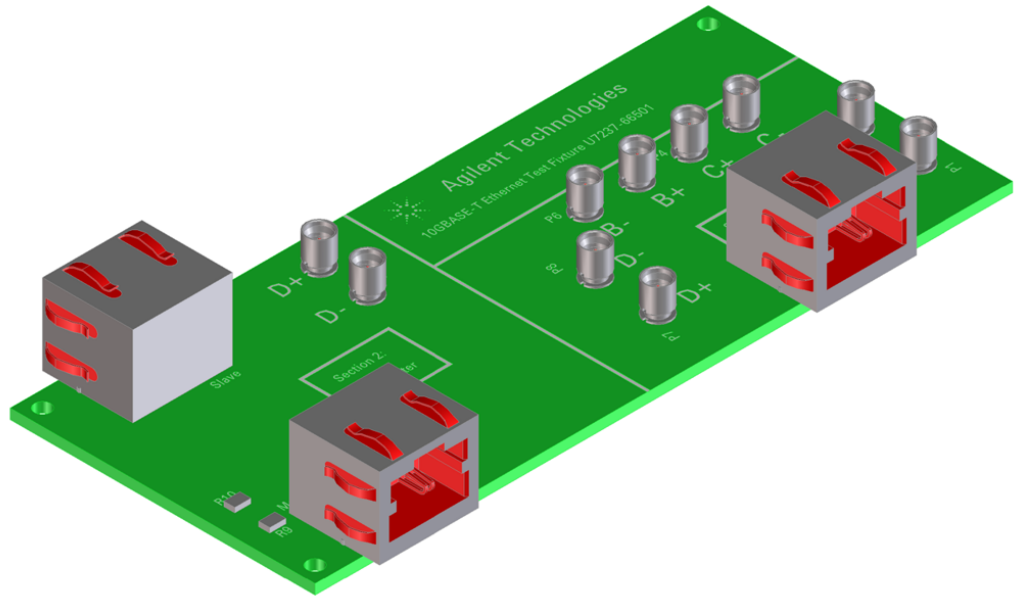

Figure 3 Section 1 and Section 2 of the U7237A 10GBASE-T Transmitter Test Fixture

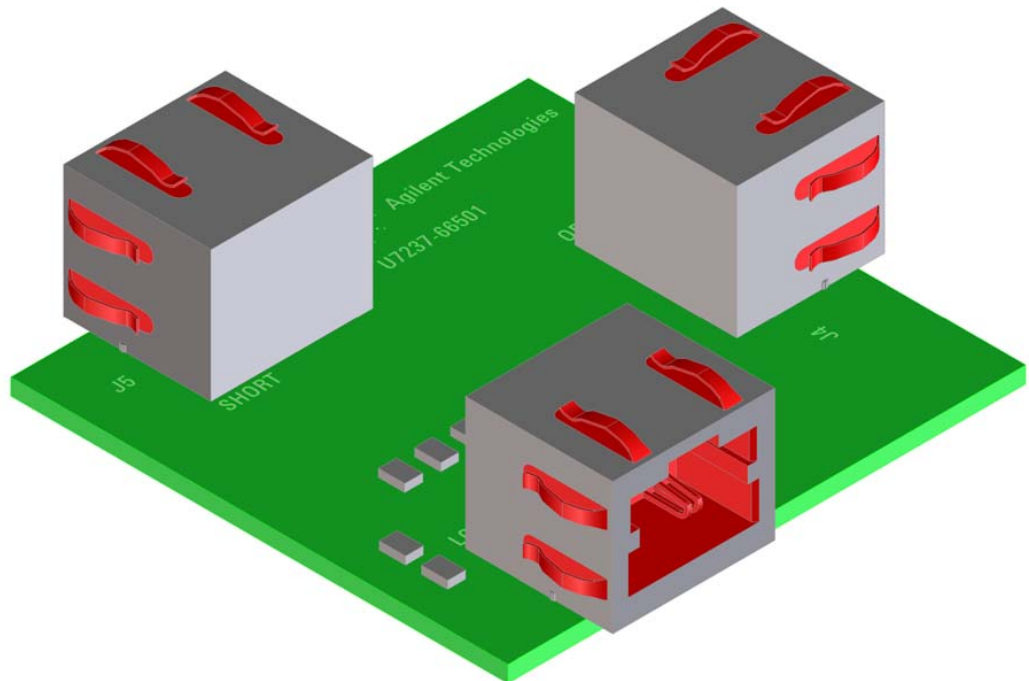

Figure 4 Section 3 of the U7237A 10GBASE-T Transmitter Test Fixture

Fixture and Accessories

The complete set of 10GBASE-T transmitter test fixture contains the following items:

Part Number	Description	Quantity
U7237-66501	10GBASE-T test fixture	1 unit
1250-3553*	50 ohm RF SMP female straight connector	6 units
N4235-61602	16 inches phase matched SMP female/SMA male cable pair	2 units
U7237-61601	8 inches 10GBASE-T shielded patch cord	2 units
0955-2095	Precision instrumentation Balun 300 KHz to 3 GHz	1 unit

* It is always recommended to mate and de-mate connectors straight up. However, this connector is capable of mating at a +/- .020" radial tolerance. In handling this connector, one should not hold or squeeze it on the interface side. Always hold it on the knurled end.

Dimension

The dimension of the U7237A test fixture board is as follows:

PCB board height = 1.89 inches

PCB board width = 6.30 inches

PCB board thickness = 0.063 inches

Test Modes

The test modes are required for testing the transmitter waveform, transmitter distortion, transmitter jitter, transmitter droop and BER testing:

- Test Mode 1 is a mode provided to enable the timing jitter testing on a SLAVE transmitter and transmit clock frequency testing.
- Test Mode 2 is for transmitter jitter testing when the transmitter is in the MASTER timing mode.
- Test Mode 3 is for transmitter jitter testing in the SLAVE mode if the loop timing is supported.
- Test Mode 4 is for the transmitter linearity testing.
- Test Mode 5 is used to verify whether the transmitter is compliant with the transmit PSD mask, the power level test and MDI return loss test.
- Test Mode 6 is for testing the transmitter droop.
- Test Mode 7 is used to enable the measurement of the bit error rate of the link.

Characteristics, Regulatory, and Safety Information

Electrical Characteristics

The following electrical characteristics are the specification of the U7237A 10GBASE-T transmitter test fixture:

Description	Specification	
Bandwidth	3 GHz	
Attenuation between the master & slave in Section 2 (3 GHz bandwidth)	15 dB \pm 1 dB (including transmission line)	
Isolation (between transmitter & Pair D)	> 30 dB	
Insertion loss	Frequency Range	Max Insertion Loss
	0- 500 MHz	< 0.5 dB
	500 MHz - 1 GHz	< 1.5 dB
	1 GHz - 2 GHz	< 3.2 dB
	2 GHz - 3 GHz	< 4.5 dB
Ethernet shielded patch cord	CAT6A	
Balun bandwidth	300 KHz to 3 GHz	

Operating and Non-operating Environmental Characteristics

The following are the environmental characteristics of the U7237A 10GBASE-T transmitter test fixture:

Description	Minimum Requirement
Ambient temperature	Operating = 0°C to 40°C Non-operating = - 51°C) to 71°C
Humidity	Operating = 95% RH at 40°C for 24 hours
Altitude	Operating = 4,570m (15,000 ft) Non-operating = 15,244m (50,000 ft)
Indoor use	This fixture is rated for indoor use only
Random vibration	HP/Agilent class B1 and MIL-PRF-2880 OF Class 3 random
Mechanical shock	HP/Agilent class B1 and MIL-PRF-2880 OF (operating 30g, 1/2 sine, 11-ms duration, 3 shocks/axis along major axis. Total of 18 shocks)

Safety Information

The U7237A 10GBASE-T transmitter test fixture herewith complies with the essential requirements of the Low Voltage Directive 73/23/EEC and the EMC Directive 89/336/EEC, and carries the CE-marking accordingly. The product was tested in a typical configuration with HP/Agilent test systems.

The following are the safety regulatory information of the U7237A 10GBASE-T transmitter test fixture:

Minimum Requirement:

IEC 61010-1: Second edition 2001-2

EN 61010-1:2001

UL3111-1 or UL 6101B-1:2003 (must be an Agilent ID)

Canada: CSA-C22.2 No. 1010.1:1992

3 U7237A 10GBASE-T Transmitter Test Fixtures

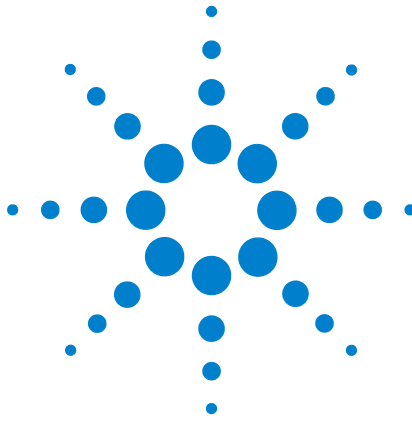

4 Transmitter Timing Jitter (MASTER) Test

Connection for Transmitter Timing Jitter (MASTER) Test 28

Transmitter Timing Jitter (MASTER) Test - Test Method of
Implementation 31

This section provides the Methods of Implementation (MOIs) for Transmitter Timing Jitter (MASTER) test using an Agilent 80000 or 90000 Series Infiniium oscilloscope, 10GBASE-T Transmitter test fixture and the 10GBASE-T Electrical Conformance Test Application.



Connection for Transmitter Timing Jitter (MASTER) Test

When performing the Transmitter Timing Jitter (MASTER) test, the 10GBASE-T Electrical Conformance Test Application will prompt you to make proper connections. The connections for the Transmitter Timing Jitter (MASTER) test may look similar to the following diagram. Refer to the Connection tab in 10GBASE-T Electrical Conformance Test Application for more details.

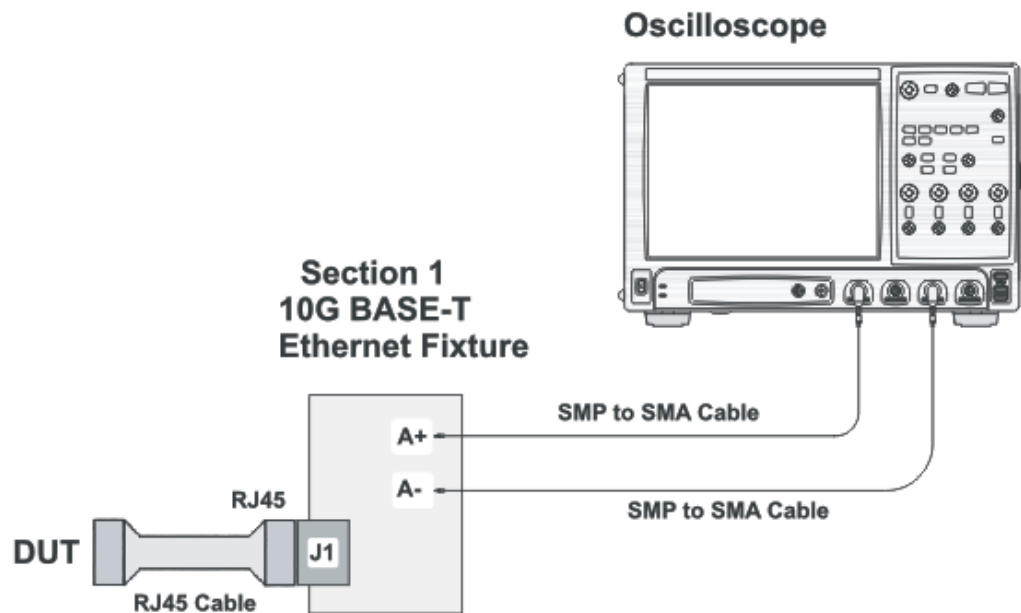

Figure 5 Connection for Transmitter Timing Jitter (MASTER) Test

You may connect the SMP to SMA cables to any of the oscilloscope channels. You can identify the channels used for each signal in the Configuration tab of the 10GBASE-T Electrical Conformance Test Application. (The channels shown in [Figure 5](#) is just an example.)

Test Procedure

- 1 Start the automated test application as described in “[Starting the 10GBASE-T Electrical Conformance Test Application](#)” on page 15.
- 2 Connect one end of the RJ45 cable to the DUT and another end to J1 connector on the Section 1 of the 10GBASE-T Transmitter test fixture.
- 3 Connect the SMP connector pairs, for example A+ and A- SMP connectors to the any two of the oscilloscope channels by using the SMP to SMA cables.

- 4 In the 10G Ethernet test application, click the Set Up tab.
- 5 Under the Connection group, check the connection pair(s) under test. You can select more than one pair of connection.
- 6 Enter your comments in the Comments text box.
- 7 Click the Select Tests tab and check the tests you want to run. Check the parent node or group to check all the available tests within the group.

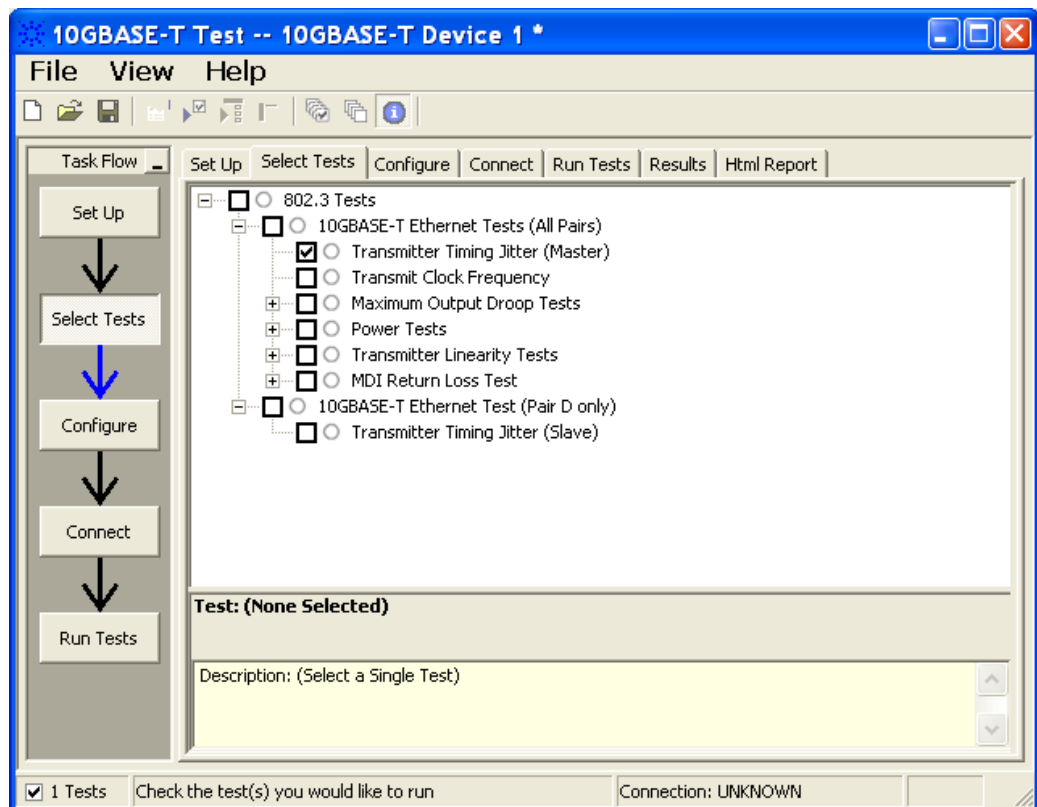

Figure 6 Selecting Transmitter Timing Jitter (MASTER) Test

- 8 Follow the 10GEthernet test application's task flow to set up the configuration options (see [Table 1](#)), run the test, and view the test results.

4 Transmitter Timing Jitter (MASTER) Test

Table 1 Test Configuration Options

Configuration Option	Description
Connection Pair (Positive)	The channel number for connection pair positive.
Connection Pair (Negative)	The channel number for connection pair negative.

Transmitter Timing Jitter (MASTER) Test - Test Method of Implementation

The purpose of the Transmitter Timing Jitter (MASTER) test is to verify that the MASTER transmitter timing jitter of the device under test (DUT) is within the conformance limits specified in clause 55.5.3.3 of *IEEE 802.3*.

For this test, the obtained timing jitter must be less than or equal to 5.5ps over a sample size of 200000 ± 20000 . This jitter value is to be verified for each of the four pairs of the 10G test mode 2 signaling for a particular DUT. These pairs are identified as Pair A, Pair B, Pair C and Pair D.

Test Definition Notes from the Specification

Clause 55.5.3.3 Transmitter Timing Jitter

RMS period jitter over an integration time interval of $1 \text{ ms} \pm 10\%$ is defined as the root mean square period difference from the average period ($T - T_{avg}$) accumulated over a sample size of 200000 ± 20000 .

$$RMS \text{ period jitter} = \sqrt{\frac{\sum [(T - T_{avg})^2]}{\text{Sample Size}}}$$

Pass Condition

The RMS period jitter measured at the MDI must be less than or equal to 5.5 ps for all the pairs.

Measurement Algorithm

- 1 Configure the MASTER DUT to produce test mode 2 signal.
- 2 Convert the single ended signal to differential signal:
 FUNC2 = Positive Connection Pair (default Channel1) subtract Negative Connection Pair (default Channel3) to get the differential signal.
- 3 Trigger on the rising edge of Positive Connection Pair. Set the trigger level to offset voltage of Positive Connection Pair.
- 4 Set the sampling rate to 20 Gsa/s.
- 5 The number of acquisitions to be taken depends on the time range and the memory depth selected by the customers:

$$\text{Number of Acq} = \text{Time Range} / (\text{Memory Depth} * 1/\text{Sampling Rate})$$

- 6 Apply the band pass filter with the parameter as shown below to the signal:
 - Center Frequency = 200 MHz

4 Transmitter Timing Jitter (MASTER) Test

- Bandwidth = 2 MHz
- 7 Enable the histogram and measure the period to the output of the band pass filter.
- 8 Take the standard deviation from the histogram statistics.
- 9 Compare the test result with the compliance test limit.

Test References

See Clause 55.5.3.3 Transmitter Timing Jitter in the *IEEE 802.3-2006 Standard*.

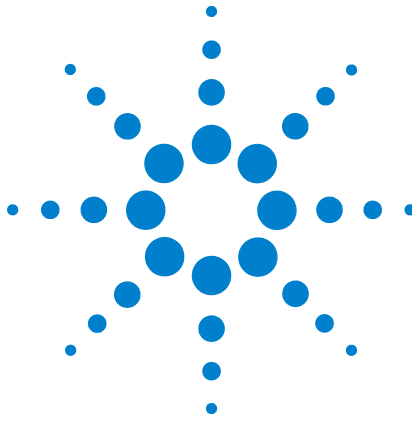

5 Transmit Clock Frequency Test

Connection for Transmit Clock Frequency Test 34

Transmit Clock Frequency Test - Test Method of Implementation 36

This section provides the Methods of Implementation (MOIs) for Transmit Clock Frequency test using an Agilent 80000 or 90000 Series Infiniium oscilloscope, 10GBASE-T Transmitter test fixture and the 10GBASE-T Electrical Conformance Test Application.



Connection for Transmit Clock Frequency Test

When performing the Transmit Clock Frequency test, the 10GBASE-T Electrical Conformance Test Application will prompt you to make proper connections. The connections for the Transmit Clock Frequency test may look similar to the following diagram. Refer to the Connection tab in 10GBASE-T Electrical Conformance Test Application for more details.

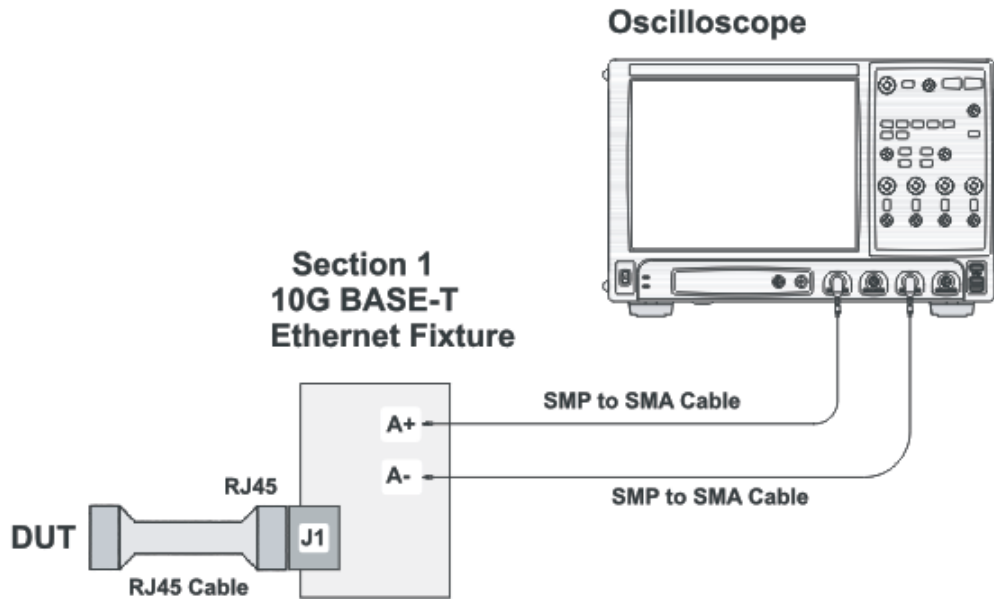

Figure 7 Connection for Transmit Clock Frequency Test

You may connect the SMP to SMA cables to any of the oscilloscope channels. You can identify the channels used for each signal in the Configuration tab of the 10GBASE-T Electrical Conformance Test Application. (The channels shown in [Figure 7](#) is just an example.)

Test Procedure

- 1 Start the automated test application as described in [“Starting the 10GBASE-T Electrical Conformance Test Application”](#) on page 15.
- 2 Connect one end of the RJ45 cable to the DUT and another end to J1 connector on the Section 1 of the 10GBASE-T Transmitter test fixture.
- 3 Connect the SMP connector pairs, for example A+ and A- SMP connectors to the any two of the oscilloscope channels by using the SMP to SMA cables.
- 4 In the 10G Ethernet test application, click the Set Up tab.

- 5 Under the Connection group, check the connection pair(s) under test. You can select more than one pair of connection.
- 6 Enter your comments in the Comments text box.
- 7 Click the Select Tests tab and check the tests you want to run. Check the parent node or group to check all the available tests within the group.

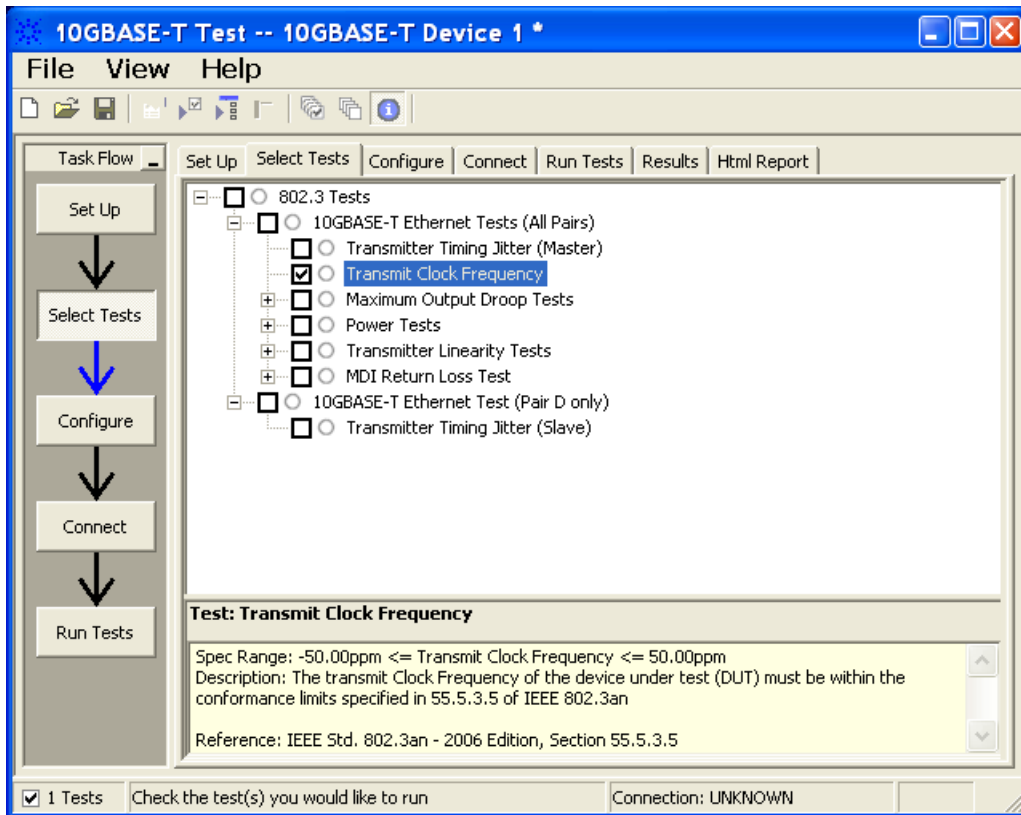

Figure 8 Selecting Transmit Clock Frequency Test

- 8 Follow the 10GEthernet test application’s task flow to set up the configuration options (see Table 2), run the test, and view the test results.

Table 2 Test Configuration Options

Configuration Option	Description
Connection Pair (Positive)	The channel number for connection pair positive.
Connection Pair (Negative)	The channel number for connection pair negative.

Transmit Clock Frequency Test - Test Method of Implementation

The purpose of the Transmit Clock Frequency test is to verify that the device under test (DUT) meets the requirements as specified in clause 55.5.3.5 of IEEE 802.3. For this test, the obtained Transmit Clock Frequency must be in the range of 800MHz +- 50ppm. This is verified for each of the four pairs of the 10G test mode 2 signaling for a particular DUT. These pairs are identified as Pair A, Pair B, Pair C and Pair D.

Test Definition Notes from the Specification

Clause 55.5.3.5 Transmit Clock Frequency

The symbol transmission rate on each pair of the MASTER PHY shall be within the range 800 MHz \pm 50ppm.

Pass Condition

The obtained Transmit Clock Frequency must be within 800 MHz \pm 50ppm.

Measurement Algorithm

- 1 Configure the DUT to produce test mode 1 signal.
- 2 Convert the single ended signal to differential signal:
FUNC2 = Positive Connection Pair (default Channel1) subtract Negative Connection Pair (default Channel3) to get the differential signal.
- 3 Trigger on the rising edge of Positive Connection Pair . Set the trigger level to offset voltage of Positive Connection Pair .
- 4 Set the sampling rate to 20 Gsa/s.
- 5 Measure the clock data rate of the FUNC2 signal with full auto clock recovery.
- 6 Compare the test result with the compliance test limit.

Test References

See Clause 55.5.3.5 Transmit Clock Frequency in the *IEEE 802.3-2006 Standard*.

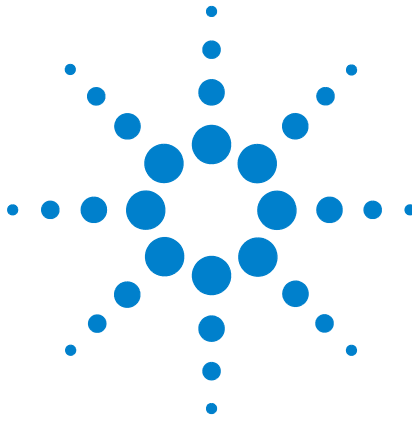

6 Maximum Output Droop Test

Connection for Maximum Output Droop Test 38

Maximum Output Droop Test - Test Method of Implementation 40

This section provides the Methods of Implementation (MOIs) for Maximum Output Droop test using an Agilent 80000 or 90000 Series Infiniium oscilloscope, 10GBASE-T Transmitter test fixture and the 10GBASE-T Electrical Conformance Test Application.



Connection for Maximum Output Droop Test

When performing the Maximum Output Droop test, the 10GBASE-T Electrical Conformance Test Application will prompt you to make proper connections. The connections for the Maximum Output Droop test may look similar to the following diagram. Refer to the Connection tab in 10GBASE-T Electrical Conformance Test Application for more details.

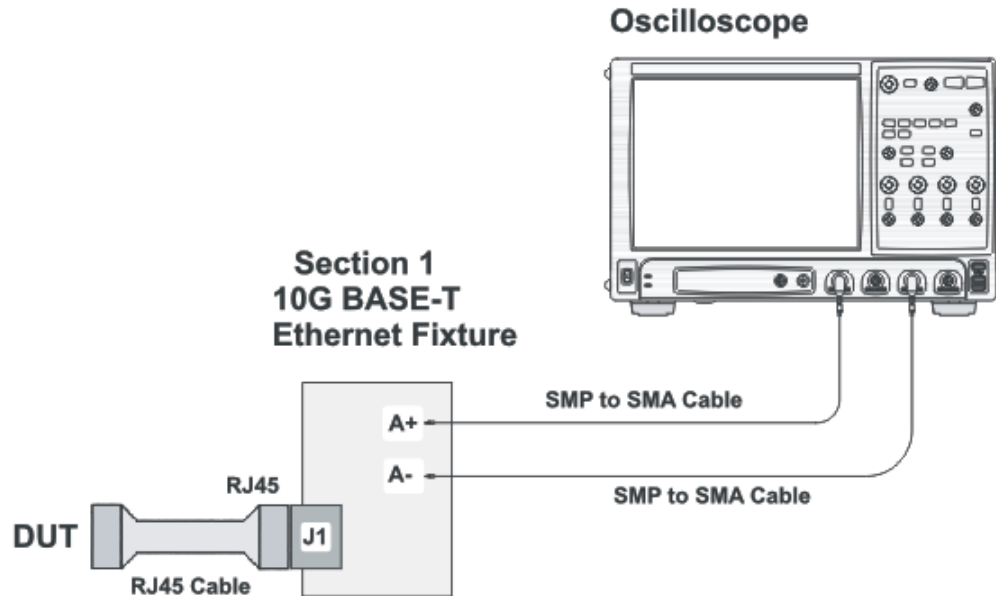

Figure 9 Connection for Maximum Output Droop Test

You may connect the SMP to SMA cables to any of the oscilloscope channels. You can identify the channels used for each signal in the Configuration tab of the 10GBASE-T Electrical Conformance Test Application. (The channels shown in [Figure 9](#) is just an example.)

Test Procedure

- 1 Start the automated test application as described in [“Starting the 10GBASE-T Electrical Conformance Test Application”](#) on page 15.
- 2 Connect one end of the RJ45 cable to the DUT and another end to J1 connector on the Section 1 of the 10GBASE-T Transmitter test fixture.
- 3 Connect the SMP connector pairs, for example A+ and A- SMP connectors to the any two of the oscilloscope channels by using the SMP to SMA cables.
- 4 In the 10G Ethernet test application, click the Set Up tab.
- 5 Under the Connection group, check the connection pair(s) under test. You can select more than one pair of connection.

- 6 Enter your comments in the Comments text box.
- 7 Click the Select Tests tab and check the tests you want to run. Check the parent node or group to check all the available tests within the group.

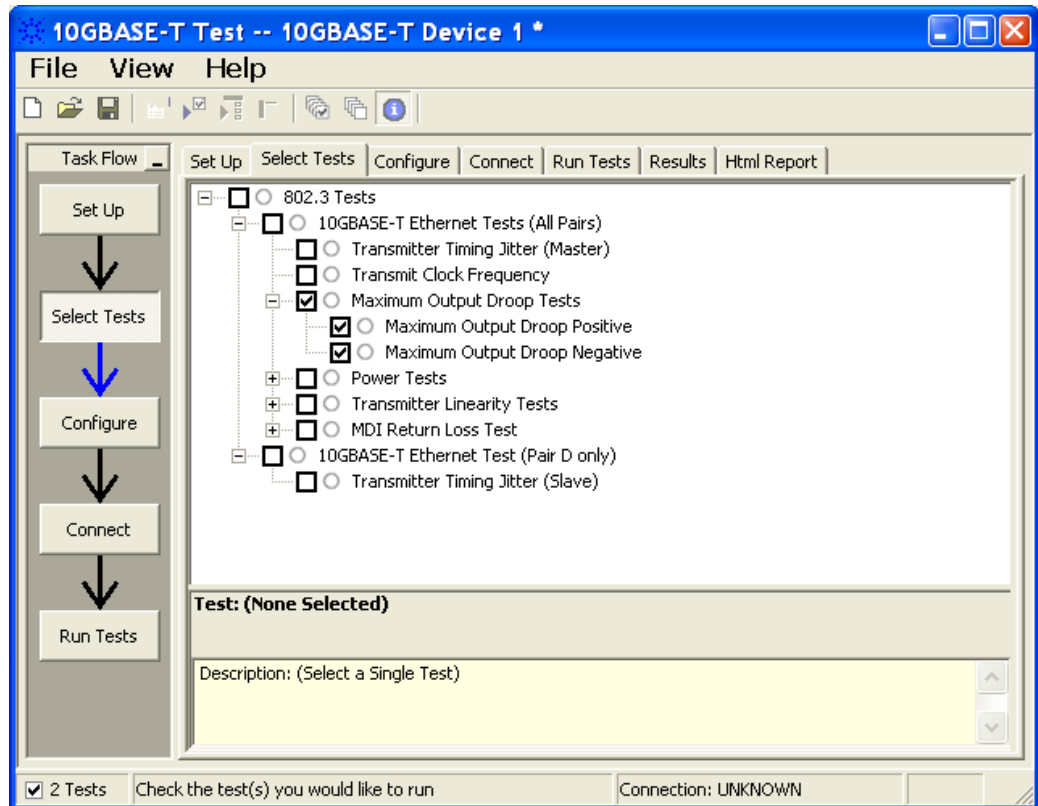

Figure 10 Selecting Maximum Output Droop Test

- 8 Follow the 10GEthernet test application’s task flow to set up the configuration options (see [Table 3](#)), run the test, and view the test results.

Table 3 Test Configuration Options

Configuration Option	Description
Connection Pair (Positive)	The channel number for connection pair positive.
Connection Pair (Negative)	The channel number for connection pair negative.

Maximum Output Droop Test - Test Method of Implementation

The purpose of the Maximum Output Droop test is to verify that the positive and negative droop of the device under test (DUT) is within the conformance limits specified in the clause 55.5.3.1 of IEEE 802.3-2006. For this test, the amplitude of both the positive and negative droop must be less than 10%, measured at initial value of 10ns after the zero cross point and final value at 90ns after the zero cross point. This droop will be verified for each of the four pairs of the 10G test mode 6 signaling for a particular DUT. These pairs are identified as Pair A, Pair B, Pair C and Pair D.

Test Definition Notes from the Specification

Clause 55.5.3.1 Maximum Output Droop

With the transmitter in test mode 6 and using the transmitter test fixture 1, the magnitude of both the positive and negative droop shall be less than 10%, measured with respect to an initial value at 10ns after the zero crossing and final value at 90 ns after the zero crossing.

Pass Condition

The average droop over all acquisitions in a given lane must be less than 10%.

Measurement Algorithm

- 1 Configure the DUT to produce test mode 6 signal.
- 2 Convert the single ended signal to differential signal:
FUNC2 = Positive Connection Pair (default Channel1) subtract Negative Connection Pair (default Channel3) to get the differential signal.
- 3 Trigger on the rising edge of Positive Connection Pair . Set the trigger level to offset voltage of Positive Connection Pair .
- 4 Set the sampling rate to 20 Gsa/s.
- 5 Measure the amplitude at 10ns reference from the trigger point.
- 6 Then, measure the amplitude at 90ns reference from the trigger point.
- 7 Calculate the droop:
$$\%droop = (10ns\ amplitude) - (90ns\ amplitude)/(10ns\ amplitude)$$
- 8 Compare the test result with the compliance test limits.

Test References

See Clause 55.5.3.1 Maximum Output Droop in the *IEEE 802.3-2006 Standard*.

6 Maximum Output Droop Test

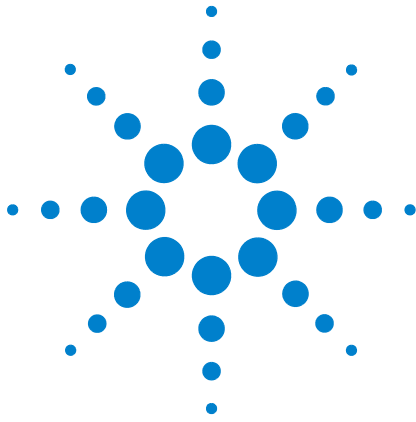

7 Transmitter Power Spectral Density Test

Connection for Transmitter Power Spectral Density Test 44

Transmitter Power Spectral Density Test - Test Method of
Implementation 50

This section provides the Methods of Implementation (MOIs) for Transmitter Power Spectral Density test using an Agilent 80000 or 90000 Series Infiniium oscilloscope, spectrum analyzer, 10GBASE-T Transmitter test fixture and the 10GBASE-T Electrical Conformance Test Application.



Connection for Transmitter Power Spectral Density Test

When performing the Transmitter Power Spectral Density test, the 10GBASE-T Electrical Conformance Test Application will prompt you to make proper connections. The connections for the Transmitter Power Spectral Density test may look similar to the following diagram. Refer to the Connection tab in 10GBASE-T Electrical Conformance Test Application for more details.

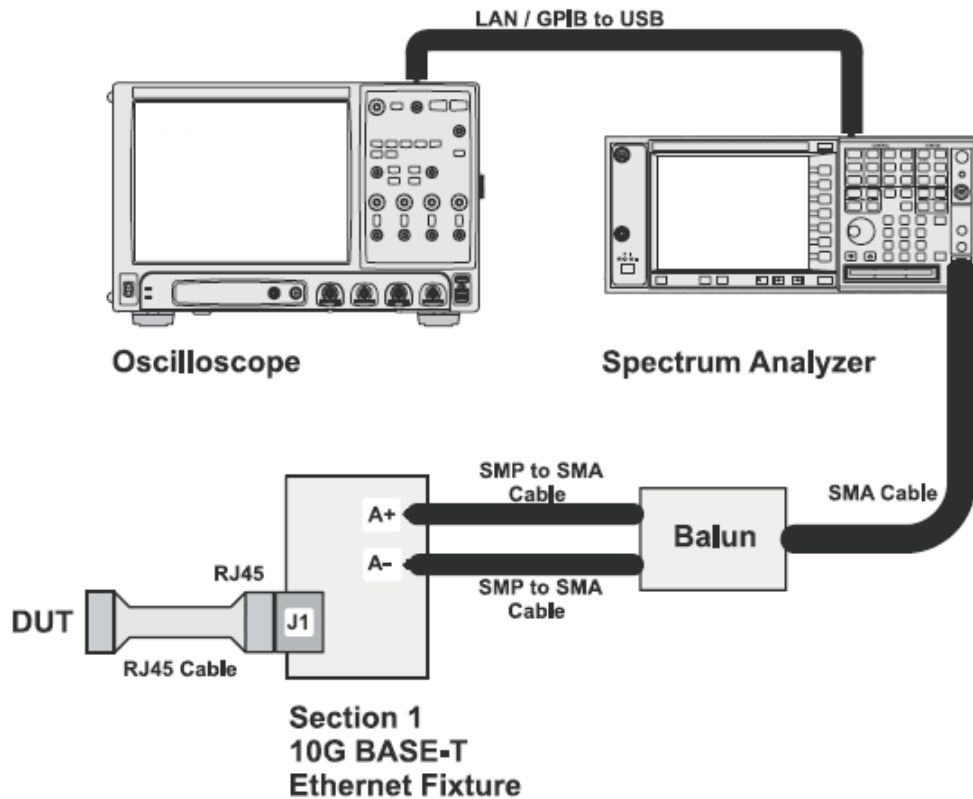

Figure 11 Connection for Transmitter Power Spectral Density Test

Test Procedure

- 1 Start the automated test application as described in "[Starting the 10GBASE-T Electrical Conformance Test Application](#)" on page 15.
- 2 Connect one end of the RJ45 cable to the DUT and another end to J1 connector on the Section 1 of the 10GBASE-T Transmitter test fixture.
- 3 Connect the SMP connector pairs, for example A+ and A- SMP connectors to the balun by using the SMP to SMA cables.
- 4 Connect the balun to the spectrum analyzer by using the SMA cable.

- 5 Use a LAN or GPIB to USB cable to connect the Spectrum Analyzer to the oscilloscope.
- 6 In the 10G Ethernet test application, click the Set Up tab.
- 7 Under the Connection group, check the connection pair(s) under test. You can select more than one pair of connection.
- 8 Ensure that the application detects the spectrum analyzer connection to the oscilloscope. Else, click on the Connect... button in the Spectrum Analyzer External Instruments group. A pop-up box will appear where you can enter either the VISA/SICL address or the IP address. Enter the information and click the Verify button, followed by the Done button to close this box. The VISA/SICL address or the IP address can be obtained from the IO Control Connection Expert application, as shown in [Figure 13](#).

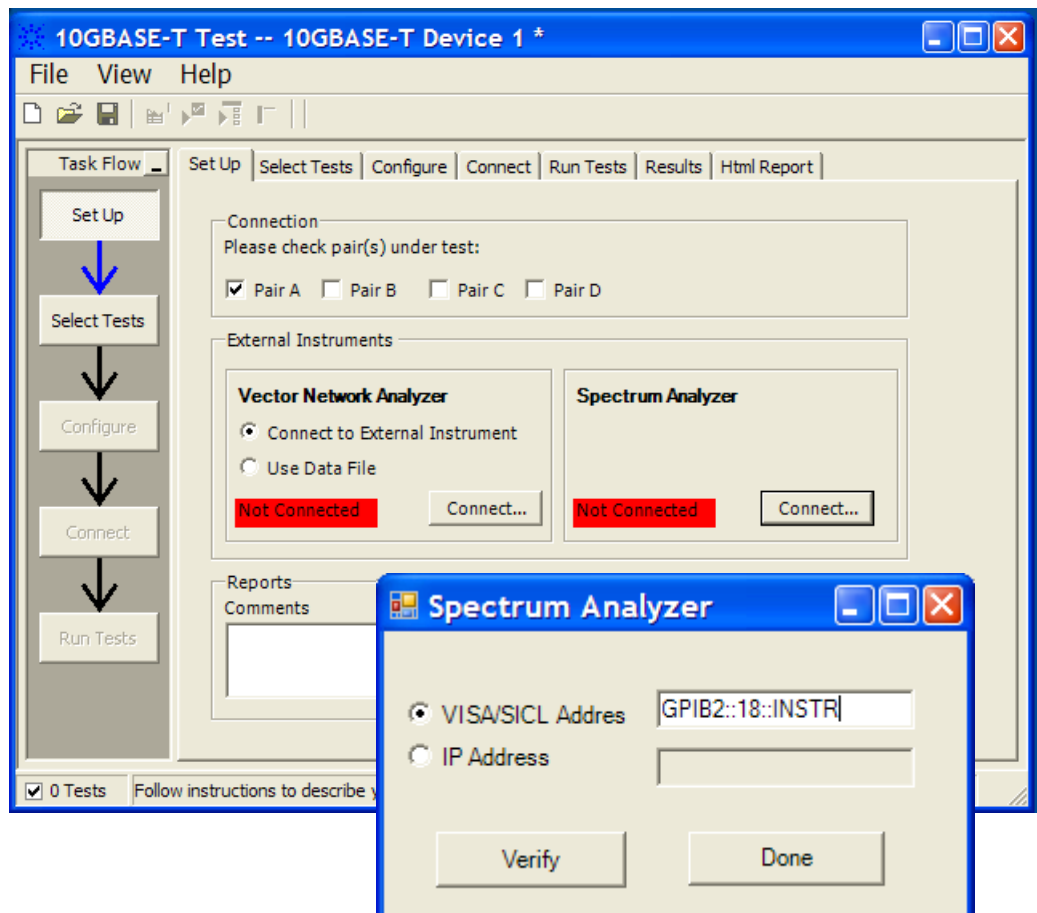

Figure 12 Setup page and spectrum analyzer pop-up box

7 Transmitter Power Spectral Density Test

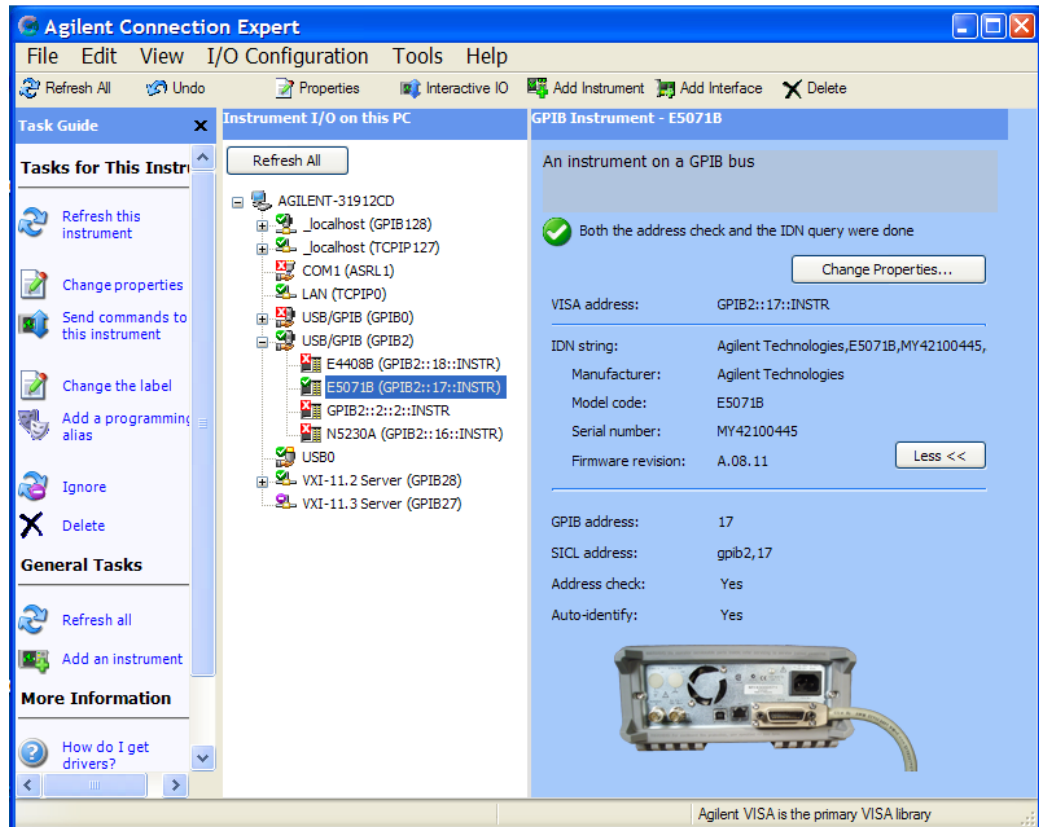

Figure 13 Agilent Connection Expert

- 9 Once the application detects the spectrum analyzer, it is indicated on the Setup page as shown in [Figure 14](#) below.

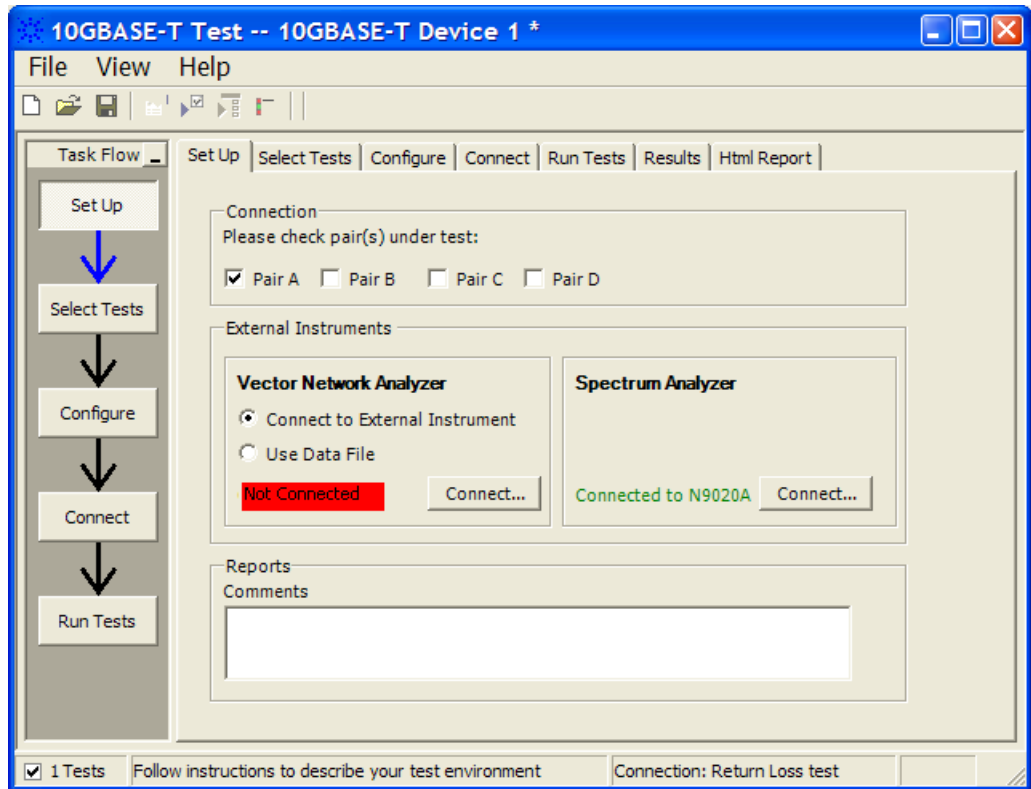

Figure 14 Setup page after application has detected the spectrum analyzer

- 10 Enter your comments in the Comments text box.
- 11 Click the Select Tests tab and check the tests you want to run. Check the parent node or group to check all the available tests within the group.

7 Transmitter Power Spectral Density Test

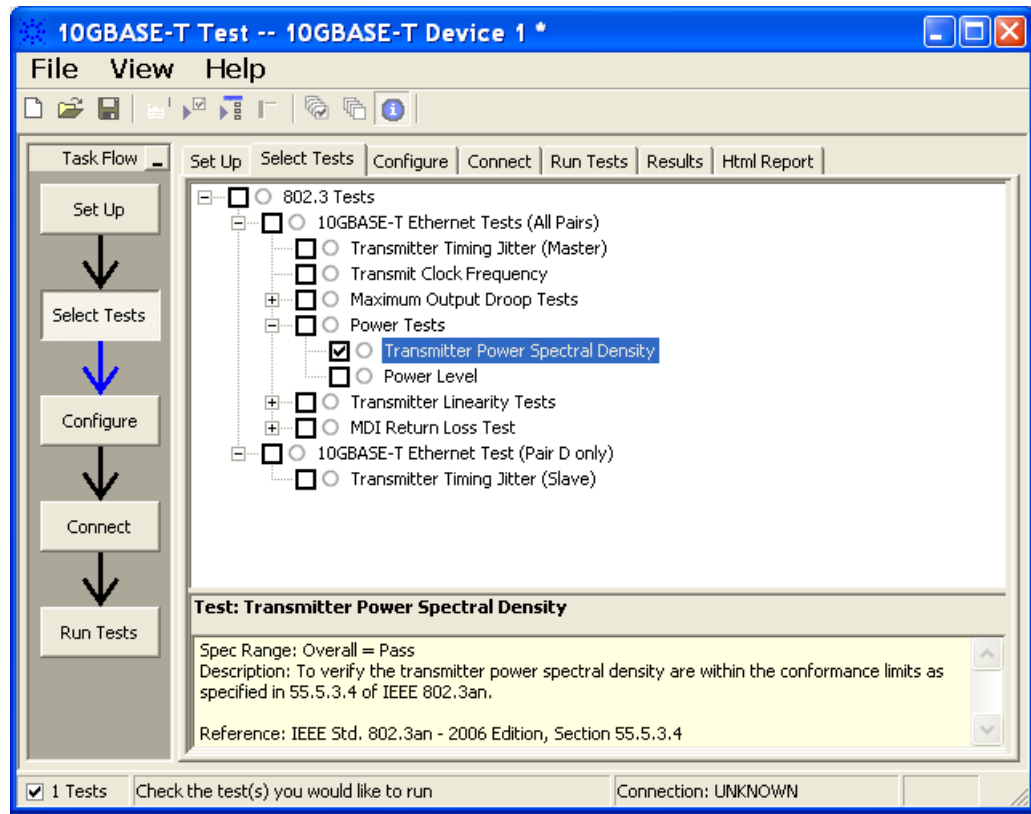

Figure 15 Selecting Power Spectral Density Test

- 12 Follow the 10GEthernet test application's task flow to set up the configuration options (see [Table 4](#)), run the test, and view the test results.

Table 4 Test Configuration Options

Configuration Option	Description
Connection Pair (Positive)	The channel number for connection pair positive.
Connection Pair (Negative)	The channel number for connection pair negative.
Power Test	
Start Frequency	The start frequency for the spectrum analyzer.
Stop Frequency	The stop frequency for the spectrum analyzer.
Resolution Bandwidth	The resolution bandwidth for the spectrum analyzer.
Reference Level	The reference level for the spectrum analyzer.
Test Type	The test type for the Power Spectral Density test.
Command File	The command file for the spectrum analyzer.

Transmitter Power Spectral Density Test - Test Method of Implementation

The purpose of the Transmitter Power Density test is to verify that the power spectral density (PSD) of the device under test (DUT) is within the conformance limits specified in clause 55.5.3.4 of *IEEE 802.3*.

The PSD of the DUT must be within the upper and lower masks as shown in Figure 16 below. PSD of the DUT is verified for each of the four lanes of test mode 5 signal. These pairs are identified as Pair A, Pair B, Pair C and Pair D.

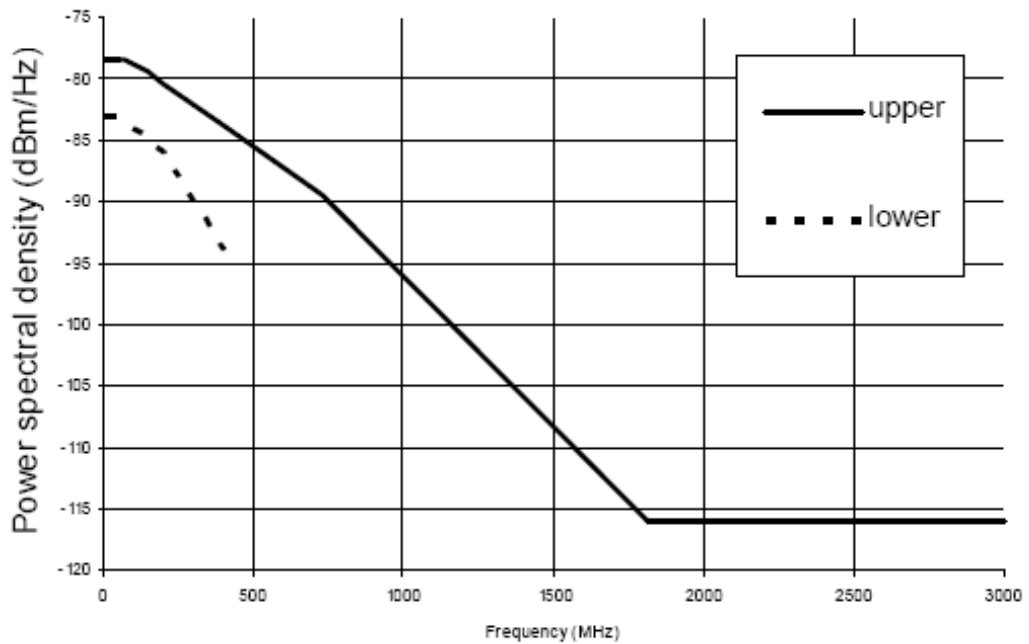

Figure 16 PSD vs. Frequency

Test Definition Notes from the Specification

Clause 55.5.3.4 Power Spectral Density

In test mode 5 (normal operation with no power backoff), the transmitted power shall be in the range of 3.2 dBm to 5.2 dBm and the power spectral density of the transmitter, measured into a 100 Ω load using the test fixture, shall be between the upper and lower masks specified in Equation (55-9) and Equation (55-10). The masks are shown graphically in Figure 16:

$$\text{Upper PSD } (f) \leq \begin{cases} -78.5 \text{ dBm/Hz} & 0 < f \leq 70 \\ -78.5 - \left(\frac{f-70}{80}\right) \text{ dBm/Hz} & 70 < f \leq 150 \\ -79.5 - \left(\frac{f-150}{58}\right) \text{ dBm/Hz} & 150 < f \leq 730 \\ -79.5 - \left(\frac{f-330}{40}\right) \text{ dBm/Hz} & 730 < f \leq 1790 \\ -116 \text{ dBm/Hz} & 1790 < f \leq 3000 \end{cases} \quad (55-9)$$

$$\text{Lower PSD } (f) \geq \begin{cases} -83 \text{ dBm/Hz} & 5 \leq f \leq 50 \\ -83 - \left(\frac{f-50}{50}\right) \text{ dBm/Hz} & 50 < f \leq 200 \\ -86 - \left(\frac{f-200}{25}\right) \text{ dBm/Hz} & 200 < f \leq 400 \end{cases} \quad (55-10)$$

Pass Condition

The signal obtained from the test mode 5 must fit within the PSD mask shown in [Figure 16](#).

Measurement Algorithm

- 1 Configure the DUT to produce test mode 5 signal.
- 2 Set the spectrum analyzer as the following:
 - Start frequency = 3 MHz and Stop frequency = 3 GHz
 - Resolution bandwidth = 3 MHz
 - Averaging (default value is 50)
 - Noise marker function
 - DC coupling (not applicable for ESA)
- 3 Collect the data from the spectrum analyzer to the application and plot the graph.
- 4 Set the SA to AC coupling mode.
- 5 Compare each point of the graph with the upper and lower limits with respective to the frequency.

Test References

See Clause 55.5.3.4 Transmitter Power Spectral Density in the *IEEE 802.3-2006 Standard*.

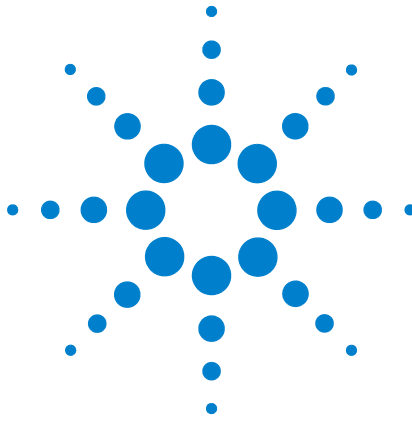

8 Power Level Test

Connection for Power Level Test 54

Power Level Test - Test Method of Implementation 60

This section provides the Methods of Implementation (MOIs) for Power Level test using an Agilent 80000 or 90000 Series Infiniium oscilloscope, spectrum analyzer, 10GBASE-T Transmitter test fixture and the 10GBASE-T Electrical Conformance Test Application.



Connection for Power Level Test

When performing the Power Level test, the 10GBASE-T Electrical Conformance Test Application will prompt you to make the proper connections. The connections for the Power Level test may look similar to the following diagram. Refer to the Connection tab in the 10GBASE-T Electrical Conformance Test Application for more details.

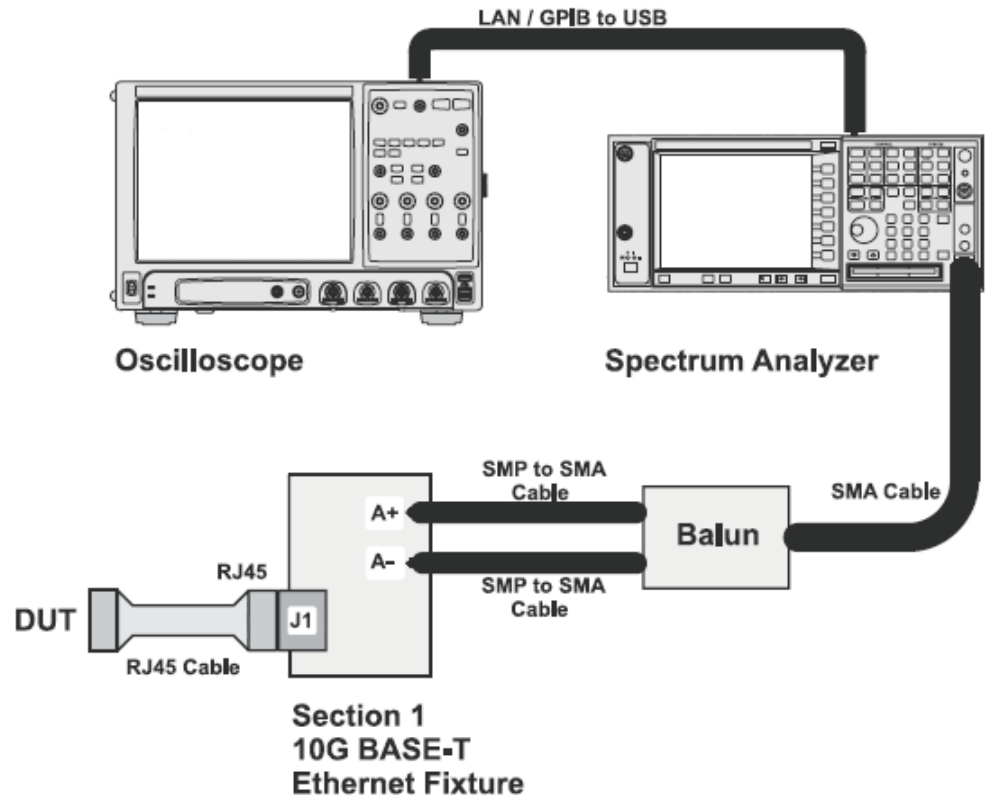

Figure 17 Connection for Power Level Test

Test Procedure

- 1 Start the automated test application as described in [“Starting the 10GBASE-T Electrical Conformance Test Application”](#) on page 15.
- 2 Connect one end of the RJ45 cable to the DUT and another end to J1 connector on the Section 1 of the 10GBASE-T Transmitter test fixture.
- 3 Connect the SMP connector pairs, for example A+ and A- SMP connectors to the Balun by using the SMP to SMA cables.
- 4 Connect the Balun to the spectrum analyzer by using the SMA cable.

- 5 Use a LAN or GPIB to USB cable to connect the spectrum analyzer to the oscilloscope.
- 6 In the 10G Ethernet test application, click the Set Up tab.
- 7 Under the Connection group, check the connection pair(s) under test. You can select more than one pair of connection.
- 8 Ensure that the application detects the spectrum analyzer connection to the oscilloscope. Else, click on the Connect... button in the Spectrum Analyzer External Instruments group. A pop-up box will appear where you can enter either the VISA/SICL address or the IP address. Enter the information and click the Verify button, followed by the Done button to close this box. The VISA/SICL address or the IP address can be obtained from the IO Control Connection Expert application, as shown in [Figure 19](#).

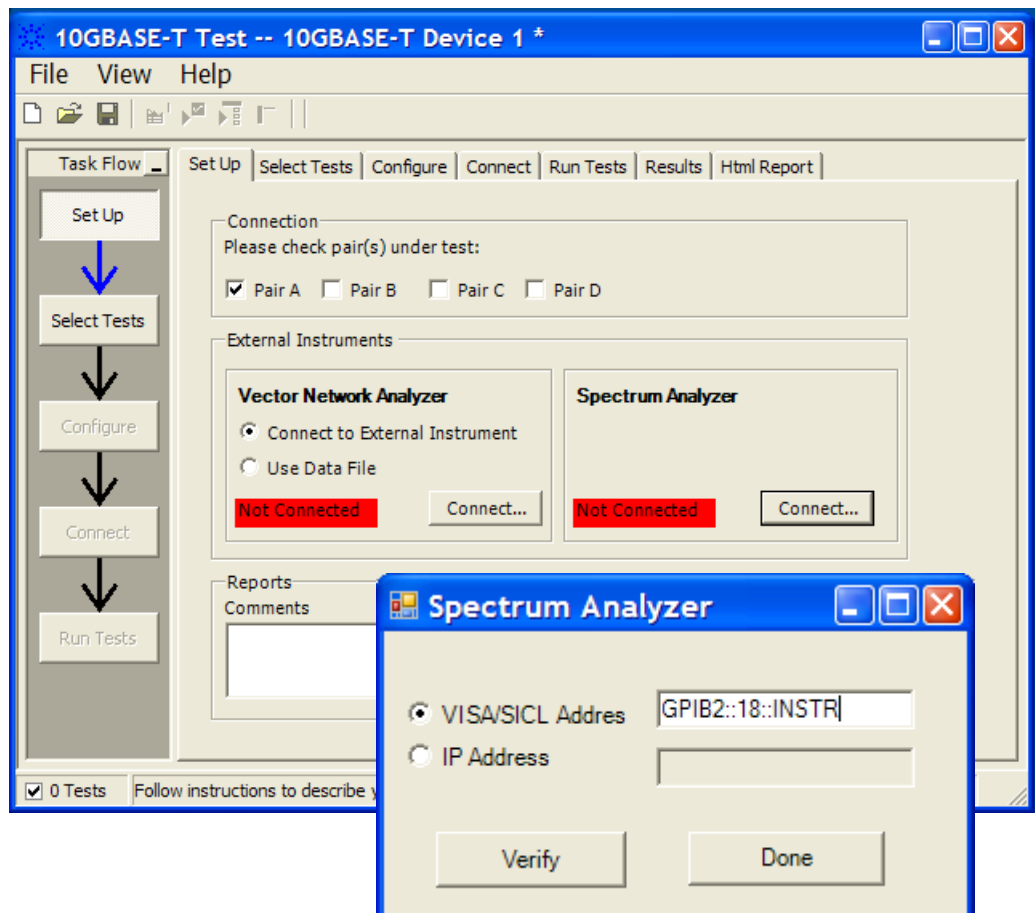

Figure 18 Setup page and spectrum analyzer pop-up box

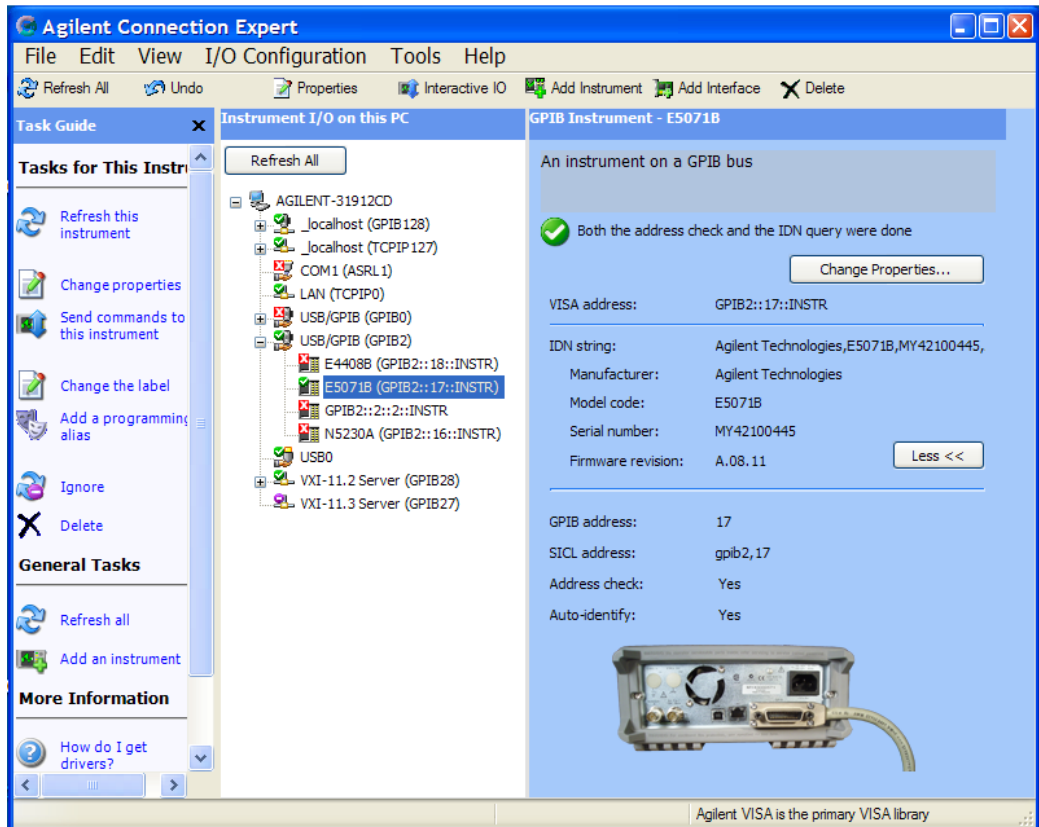

Figure 19 Agilent Connection Expert

- 9 Once the application detects the spectrum analyzer, it is indicated on the Setup page as shown in Figure 20 below.

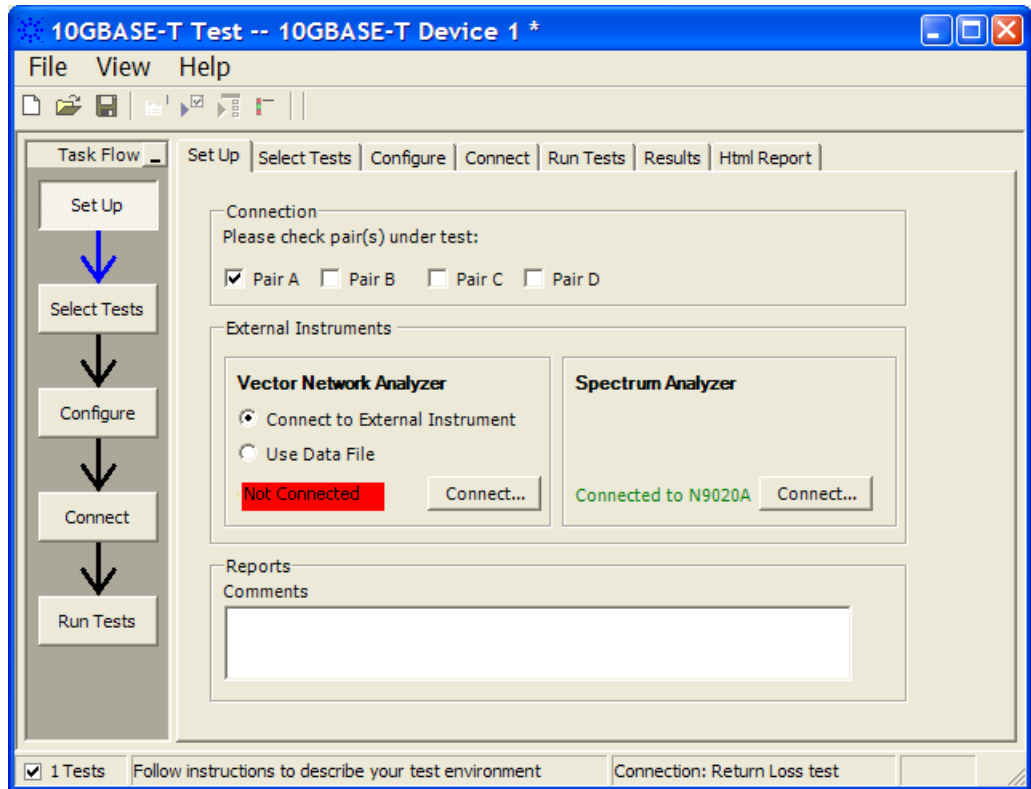

Figure 20 Setup page after application has detected the spectrum analyzer

- 10 Enter your comments in the Comments text box.
- 11 Click the Select Tests tab and check the tests you want to run. Check the parent node or group to check all the available tests within the group.

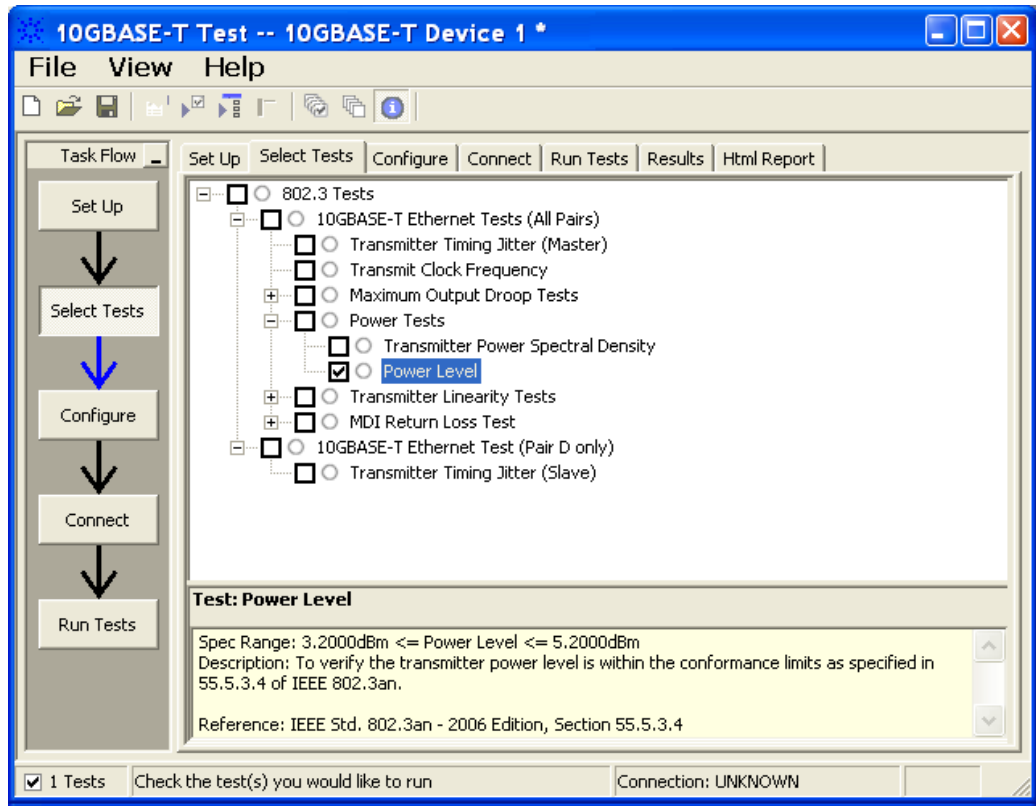

Figure 21 Selecting Power Level Test

- 12 Follow the 10GEthernet test application’s task flow to set up the configuration options (see [Table 5](#)), run the test, and view the test results.

Table 5 Test Configuration Options

Configuration Option	Description
Connection Pair (Positive)	The channel number for connection pair positive.
Connection Pair (Negative)	The channel number for connection pair negative.
Power Test	
Start Frequency	The start frequency for the spectrum analyzer.
Stop Frequency	The stop frequency for the spectrum analyzer.
Resolution Bandwidth	The resolution bandwidth for the spectrum analyzer.
Test Type	The test type for the Power Level test.
Command File	The command file for the spectrum analyzer.

Power Level Test - Test Method of Implementation

The purpose of the Power Level test is to verify that the power level of the device under test (DUT) meets the specification requirement as specified in clause 55.5.3.4 of *IEEE 802.3*.

For this test, the obtained power level must be between 3.2dBm and 5.2dBm. This value is verified for each of the four pairs of the 10G test mode 5 signaling for a particular DUT. These pairs are identified as Pair A, Pair B, Pair C and Pair D.

Test Definition Notes from the Specification

Clause 55.5.3.4 Power Spectral Density

In test mode 5 (normal operation with no power backoff), the transmit power shall be in the range 3.2 dBm to 5.2 dBm and the power spectral density of the transmitter, measured into a 100 Ω load using the test fixture, shall be between the upper and lower masks specified in Equation (55-9) and Equation (55-10).

$$\text{Upper PSD } (f) \leq \begin{cases} -78.5 \text{ dBm/Hz} & 0 < f \leq 70 \\ -78.5 - \left(\frac{f-70}{80}\right) \text{ dBm/Hz} & 70 < f \leq 150 \\ -79.5 - \left(\frac{f-150}{58}\right) \text{ dBm/Hz} & 150 < f \leq 730 \\ -79.5 - \left(\frac{f-330}{40}\right) \text{ dBm/Hz} & 730 < f \leq 1790 \\ -116 \text{ dBm/Hz} & 1790 < f \leq 3000 \end{cases} \quad (55-9)$$

$$\text{Lower PSD } (f) \geq \begin{cases} -83 \text{ dBm/Hz} & 5 \leq f \leq 50 \\ -83 - \left(\frac{f-50}{50}\right) \text{ dBm/Hz} & 50 < f \leq 200 \\ -86 - \left(\frac{f-200}{25}\right) \text{ dBm/Hz} & 200 < f \leq 400 \end{cases} \quad (55-10)$$

Pass Condition

The obtained Power Level must be between 3.2dBm and 5.2dBm from the frequency range of 3 MHz to 400 MHz.

Measurement Algorithm

- 1 Configure the DUT to produce test mode 5 signal.
- 2 Set the spectrum analyzer as the following:
 - Start frequency = 3 MHz, Stop frequency = 400 MHz
 - Resolution bandwidth = 3 MHz
 - Averaging (default value is 50)
 - Band/Interval Power marker function
 - DC coupling (not applicable for ESA)
- 3 Measure the Power Level within range of 3 MHz to 400 MHz.
- 4 Collect the data from the spectrum analyzer to the application and plot the graph.
- 5 Set the SA to AC coupling mode.
- 6 Compare the test result with the compliance test limit.

Test References

See Clause 55.5.3.4 Power Level in the *IEEE 802.3-2006 Standard*.

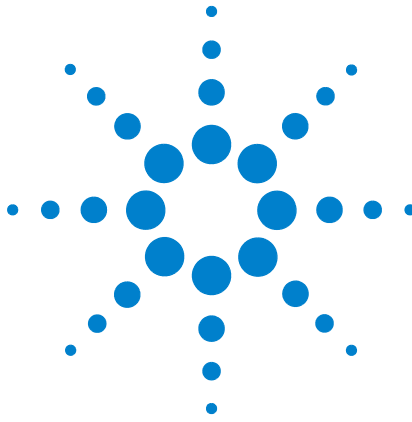

9 Transmitter Linearity Tests

Connection for Transmitter Linearity Tests 64

Transmitter Linearity Tests - Test Method of Implementation 70

This section provides the Methods of Implementation (MOIs) for Transmitter Linearity tests using an Agilent 80000 or 90000 Series Infiniium oscilloscope, spectrum analyzer, 10GBASE-T Transmitter test fixture and the 10GBASE-T Electrical Conformance Test Application.



Connection for Transmitter Linearity Tests

When performing the Transmitter Linearity tests, the 10GBASE-T Electrical Conformance Test Application will prompt you to make proper connections. The connections for the Transmitter Linearity tests may look similar to the following diagram. Refer to the Connection tab in the 10GBASE-T Electrical Conformance Test Application for more details.

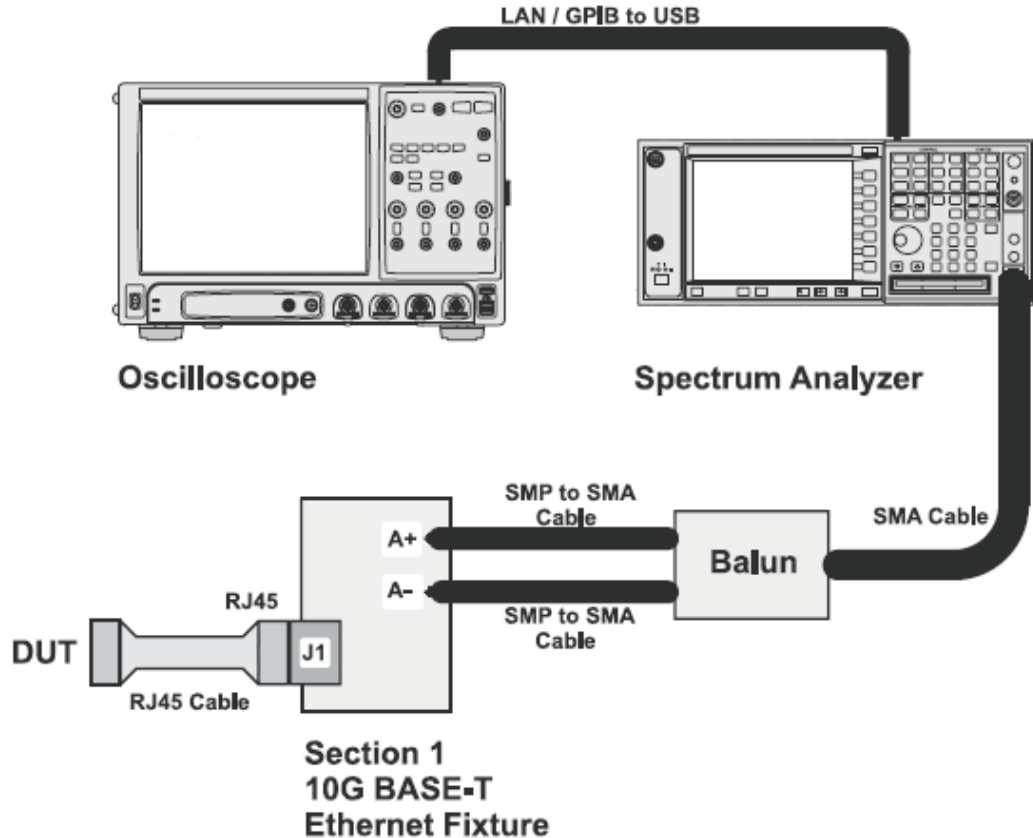

Figure 22 Connection for Transmitter Linearity Tests

Test Procedure

- 1 Start the automated test application as described in [“Starting the 10GBASE-T Electrical Conformance Test Application”](#) on page 15.
- 2 Connect one end of the RJ45 cable to the DUT and another end to J1 connector on the Section 1 of the 10GBASE-T Transmitter test fixture.
- 3 Connect the SMP connector pairs, for example A+ and A- SMP connectors to the Balun by using the SMP to SMA cables.
- 4 Connect the Balun to the spectrum analyzer by using the SMA cable.

- 5 Use a LAN or GPIB to USB cable to connect the spectrum analyzer to the oscilloscope.
- 6 In the 10G Ethernet test application, click the Set Up tab.
- 7 Under the Connection group, check the connection pair(s) under test. You can select more than one pair of connection.
- 8 Ensure that the application detects the spectrum analyzer connection to the oscilloscope. Else, click on the Connect... button in the Spectrum Analyzer External Instruments group. A pop-up box will appear where you can enter either the VISA/SICL address or the IP address. Enter the information and click the Verify button, followed by the Done button to close this box. The VISA/SICL address or the IP address can be obtained from the IO Control Connection Expert application, as shown in [Figure 24](#).

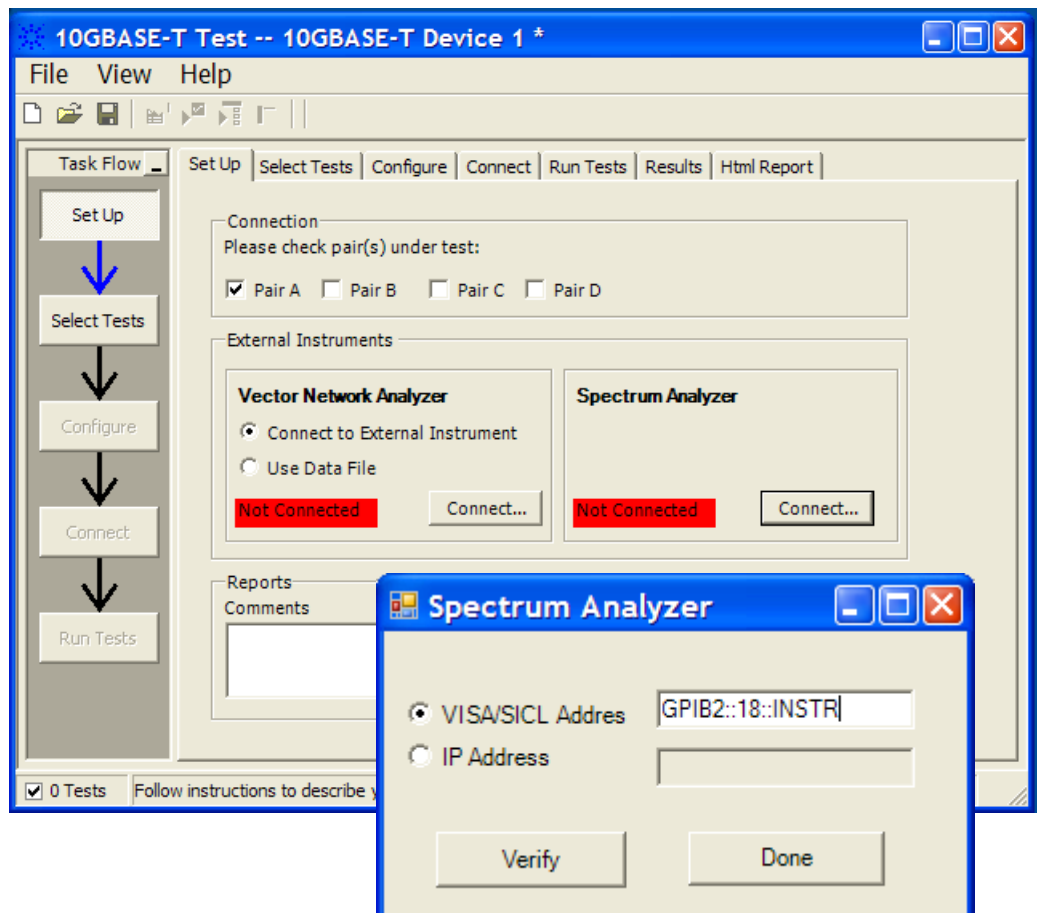

Figure 23 Setup page and spectrum analyzer pop-up box

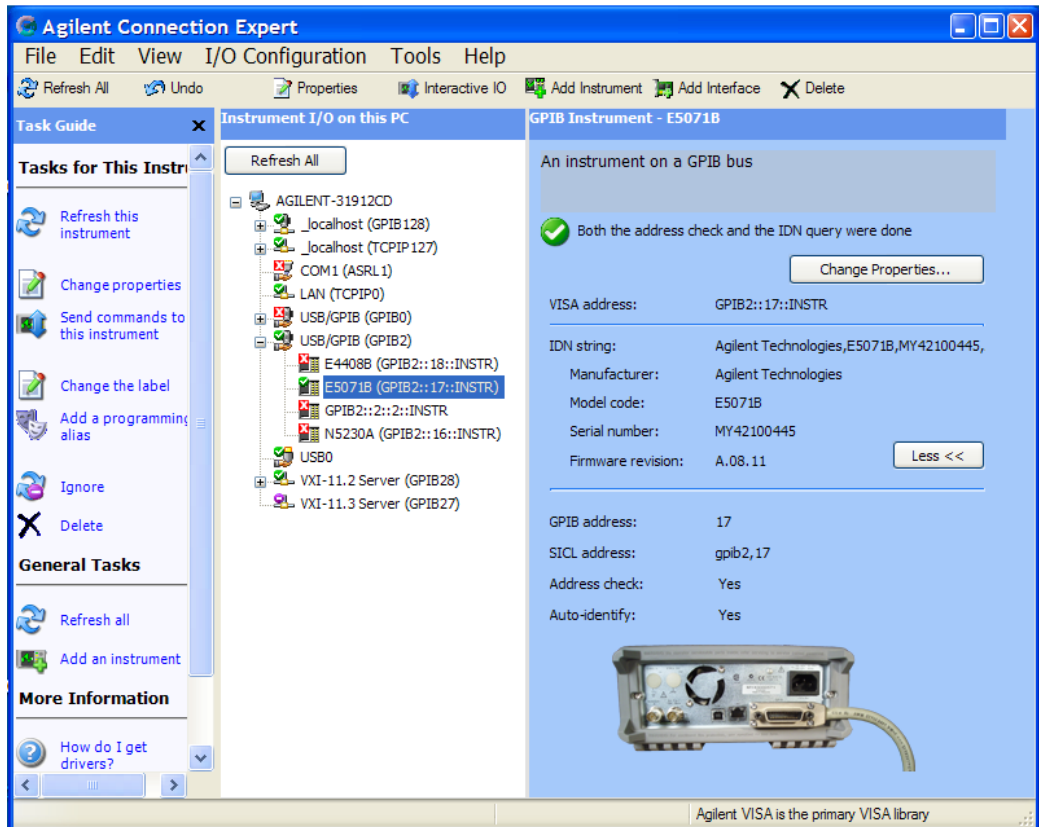

Figure 24 Agilent Connection Expert

- Once the application detects the spectrum analyzer, it is indicated on the Setup page as shown in Figure 25 below.

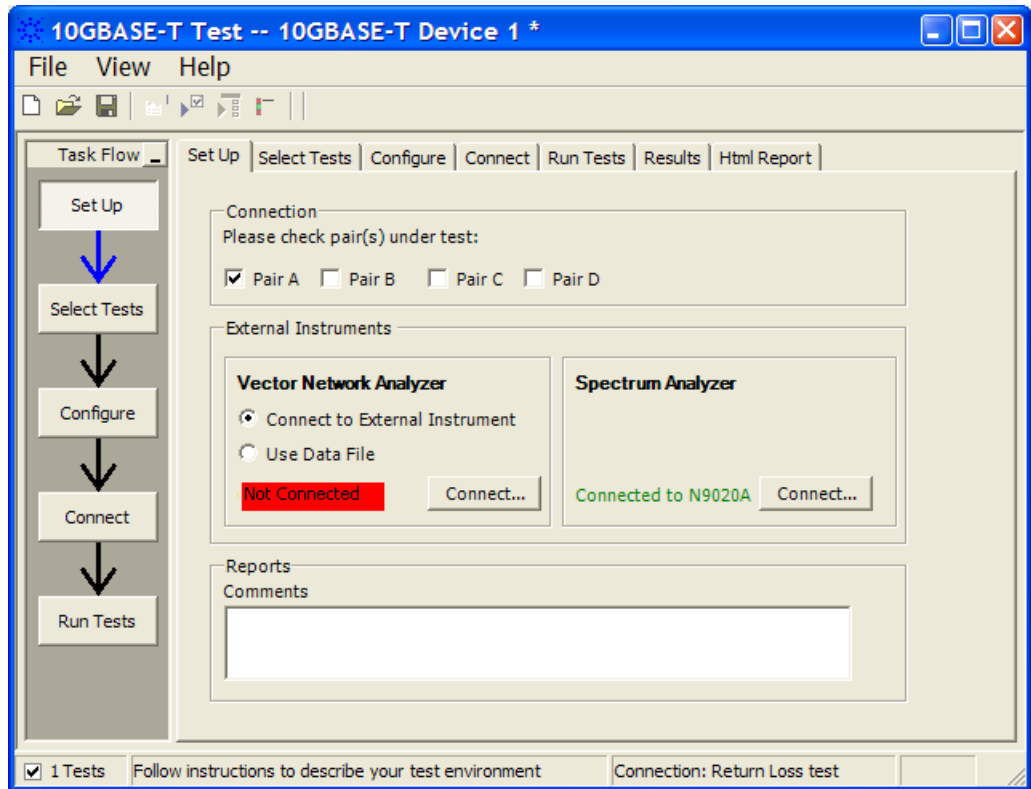

Figure 25 Setup page after application has detected the spectrum analyzer

- 10 Enter your comments in the Comments text box.
- 11 Click the Select Tests tab and check the tests you want to run. Check the parent node or group to check all the available tests within the group.

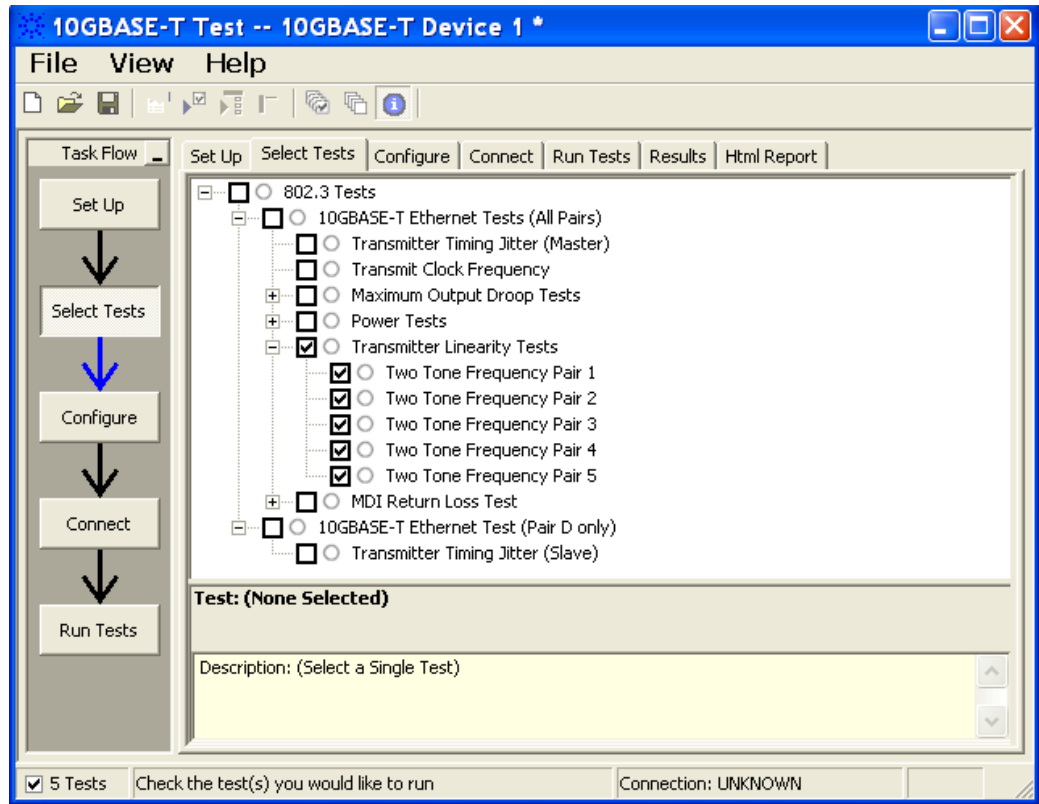

Figure 26 Selecting Transmitter Linearity Tests

- 12 Follow the 10GEthernet test application’s task flow to set up the configuration options (see [Table 6](#)), run the test, and view the test results.

Table 6 Test Configuration Options

Configuration Option	Description
Connection Pair (Positive)	The channel number for connection pair positive.
Connection Pair (Negative)	The channel number for connection pair negative.
Transmitter Linearity Tests	
Start Frequency	The start frequency for the spectrum analyzer.
Stop Frequency	The stop frequency for the spectrum analyzer.
Resolution Bandwidth	The resolution bandwidth for the spectrum analyzer.
Reference Level	The reference level for the spectrum analyzer.
Intermodulation Tolerance	The tolerance for intermodulation.
Test Type	The test type for Transmitter Linearity tests.
Command File	The command file for the spectrum analyzer.

Transmitter Linearity Tests - Test Method of Implementation

The purpose of the Transmitter Linearity tests is to verify that the device under test (DUT) conforms to the Spurious Free Dynamic Range (SFDR) requirements specified in clause 55.5.3.2 of IEEE 802.3-2006.

This SFDR will be verified for each of the four pairs of 10G test mode 4 with dual tone input signaling for a particular DUT. These pairs are identified as Pair A, Pair B, Pair C and Pair D.

Test Definition Notes from the Specification

Clause 55.5.3.2 Transmitter Linearity

When in test mode 4 and observing the spectrum of the differential signal output at the MDI using transmitter test fixture 2, for each pair, with no intervening cable, the transmitter linearity mask is defined as follows:

The SFDR of the transmitter, with dual tone inputs as specified in test mode 4, shall meet the requirement that:

$$\text{SFDR} \geq 2.5 + \min\{52, 58 - 20 \times \log_{10}(f/25)\} \quad (55-7)$$

where f is the maximum frequency of the two test tones in MHz and SFDR is the ratio in dB of the minimum RMS value of either input tone to the RMS value of the worst inter-modulation product in the frequency range of 1 MHz to 400 MHz.

This specification on transmit linearity is derived from the requirement for interoperability with the far-end device.

Pass Condition

- 1 The SFDR of the transmitter for each Lane should meet the below requirement:

$$\text{SFDR} \geq 2.5 + \min \{52, 58 - 20\log_{10}(f/25)\}$$

Where, f = maximum frequency of the two test tones

SFDR = Ratio of the minimum RMS value between two input tone and worst intermodulation product of RMS.

- 2 The test limit of SFDR for each Lane should be different for different transmit frequency.

Table 7 The Test Limit of SFDR

Transmit Frequency	Frequency Pair (dBm)	Test Limit
1	36.718 & 41.406	≥ 54.5 dBm
2	78.906 & 80.469	≥ 50.346 dBm
3	139.844 & 141.406	≥ 45.449 dBm
4	216.406 & 219.531	≥ 41.629 dBm
5	310.156 & 313.281	≥ 38.540 dBm

Measurement Algorithm

- 1 Configure the DUT to produce test mode 4 signal.
- 1 Set the test frequency.
- 2 Set the spectrum analyzer as below:
 - Start frequency = 1 MHz
 - Stop frequency = 400 MHz
 - Resolution bandwidth = 300 kHz
 - Averaging (default value is 50)
 - DC coupling (not applicable for ESA)
- 3 Collect data from the spectrum analyzer to the application in the oscilloscope and plot the graph.
- 4 Calculate the Intermodulation Product Frequency with the below equation:

Even Order = $n(A+B)$, $n(A-B)$

where, $n = 2,4,6,8,10,\dots,120$

Odd Order = $N(A) - (N-1)(B)$, $N(B) - (N-1)(A)$

where, $N = n - ((n/2)-0.5)$ and $n = 3,5,7,9,\dots,119$
- 5 Keep the list of the calculated frequency, L1.
- 6 Get the peak product frequency from the spectrum analyzer and keep it in another list, L2.
- 7 Compare L1 with L2 and keep the list of the peak value (obtained from the spectrum analyzer), L3 with the below condition:
 - Frequency values close (with default tolerance of 500 kHz) to the frequency in L1.
- 8 SFDR = Highest Peak (L3) - Third highest Peak (L3)
- 9 Set the spectrum analyzer to AC coupling.

10 Compare the test result with the compliance test limit.

Test References

See Clause 55.5.3.2 Transmitter Linearity in the *IEEE 802.3-2006 Standard*.



10 MDI Return Loss Test

Connection for MDI Return Loss Test 74

MDI Return Loss Test - Test Method of Implementation 82

This section provides the Methods of Implementation (MOIs) for MDI Return Loss test using an Agilent 80000 or 90000 Series Infiniium oscilloscope, vector network analyzer, 10GBASE-T Transmitter test fixture and the 10GBASE-T Electrical Conformance Test Application.



Connection for MDI Return Loss Test

When performing the MDI Return Loss test, the 10GBASE-T Electrical Conformance Test Application will prompt you to make proper connections. The connections for the MDI Return Loss test may look similar to the following diagram. Refer to the Connection tab in 10GBASE-T Electrical Conformance Test Application for more details.

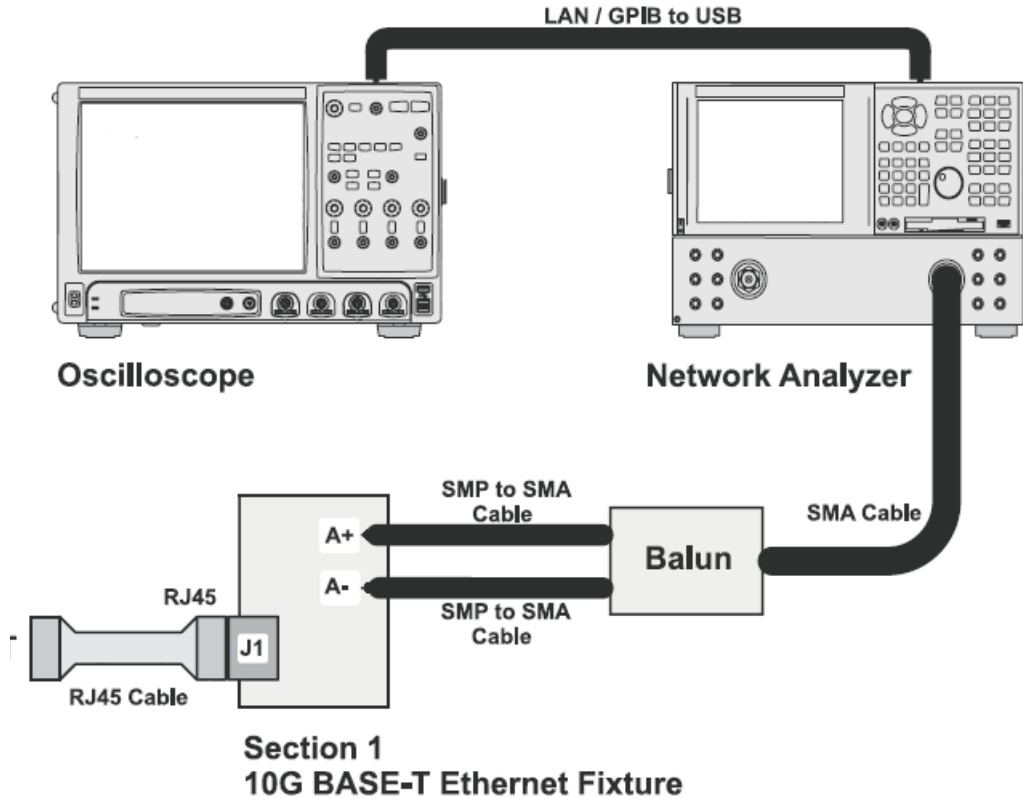

Figure 27 Connection for MDI Return Loss Test

Test Procedure

- 1 Start the automated test application as described in “[Starting the 10GBASE-T Electrical Conformance Test Application](#)” on page 15.
- 2 Connect one end of the RJ45 cable to the DUT and another end to J1 connector on the Section 1 of the 10GBASE-T Transmitter test fixture.
- 3 Connect the SMP connector pairs, for example A+ and A- SMP connectors to the Balun by using the SMP to SMA cables.
- 4 Connect the Balun to the vector network analyzer by using the SMA cable.

- 5 Use a LAN or GPIB to USB cable to connect the vector network analyzer to the oscilloscope.
- 6 In the 10G Ethernet test application, click the Set Up tab.
- 7 Under the Connection group, check the connection pair(s) under test. You can select more than one pair of connection.
- 8 Ensure that the application detects the vector network analyzer connection to the oscilloscope. Else, click on the Connect... button in the Vector Network Analyzer External Instruments group. A pop-up box will appear where you can enter either the VISA/SICL address or the IP address. Enter the information and click the Verify button, followed by the Done button to close this box. The VISA/SICL address or the IP address can be obtained from the IO Control Connection Expert application, as shown in [Figure 28](#).

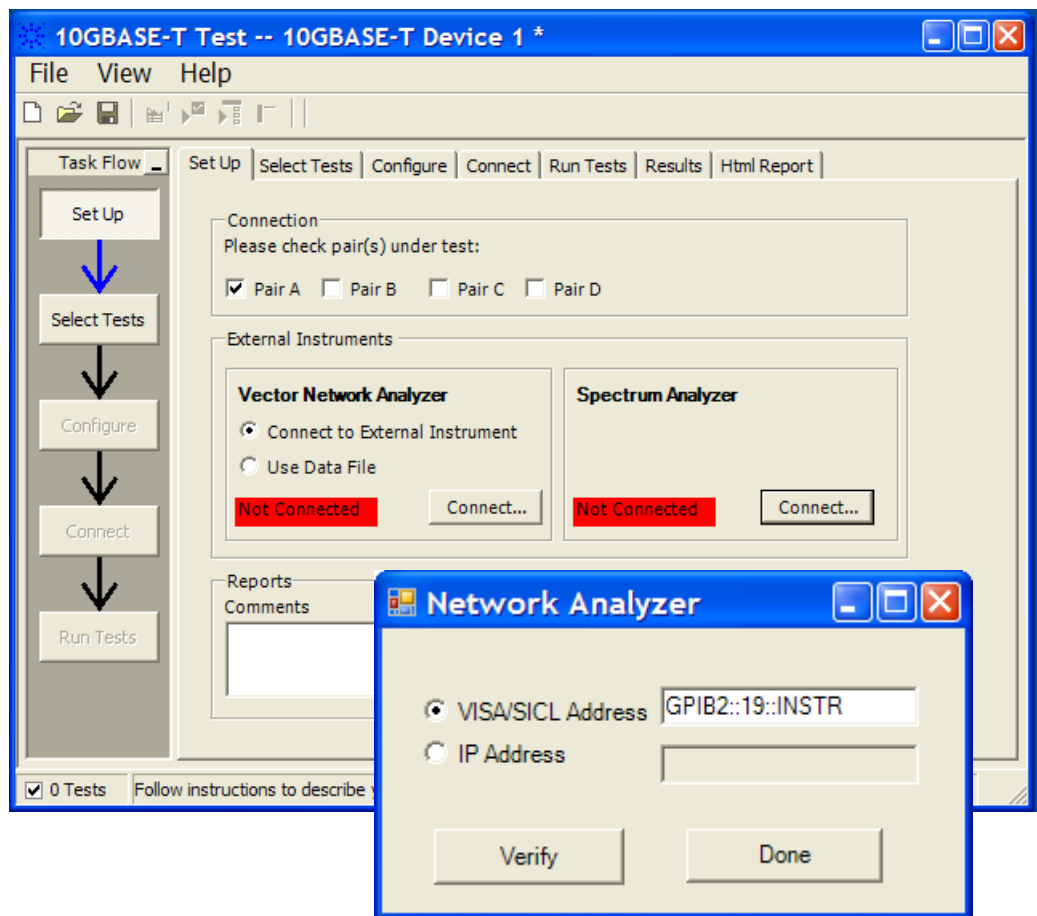

Figure 28 Setup page and vector network analyzer pop-up box

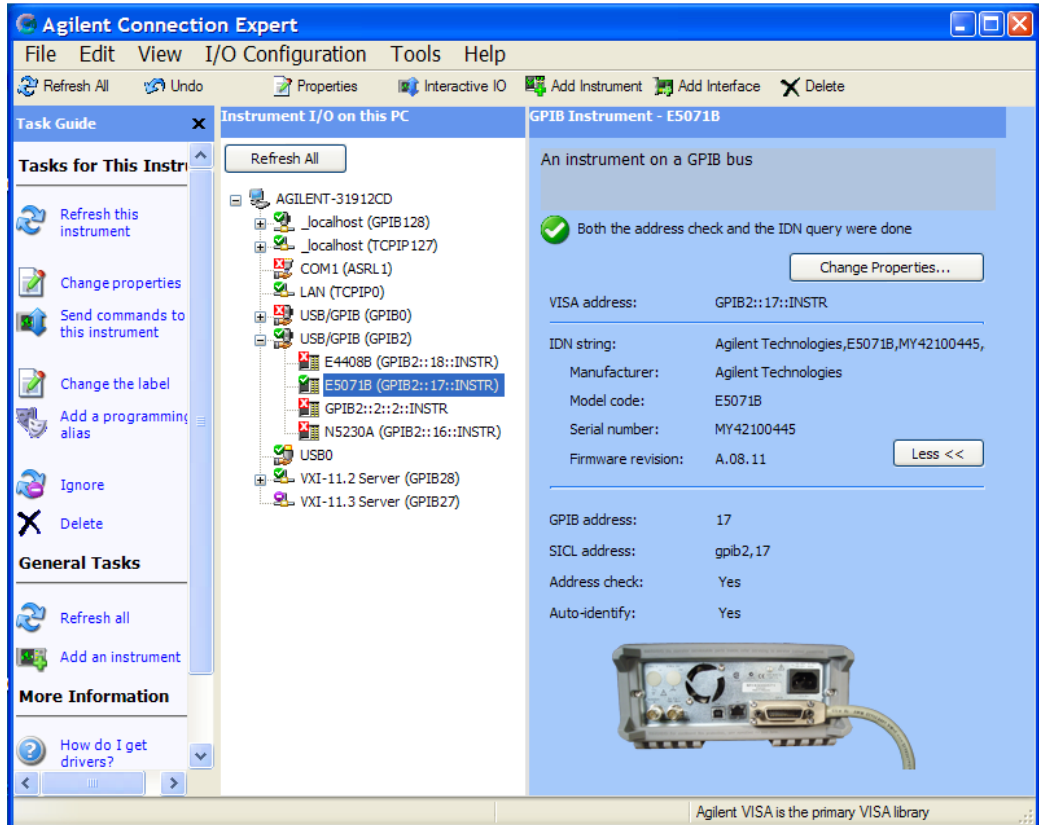

Figure 29 Agilent Connection Expert

- 9 Once the application detects the vector network analyzer, it is indicated on the Setup page as shown in Figure 30 below.

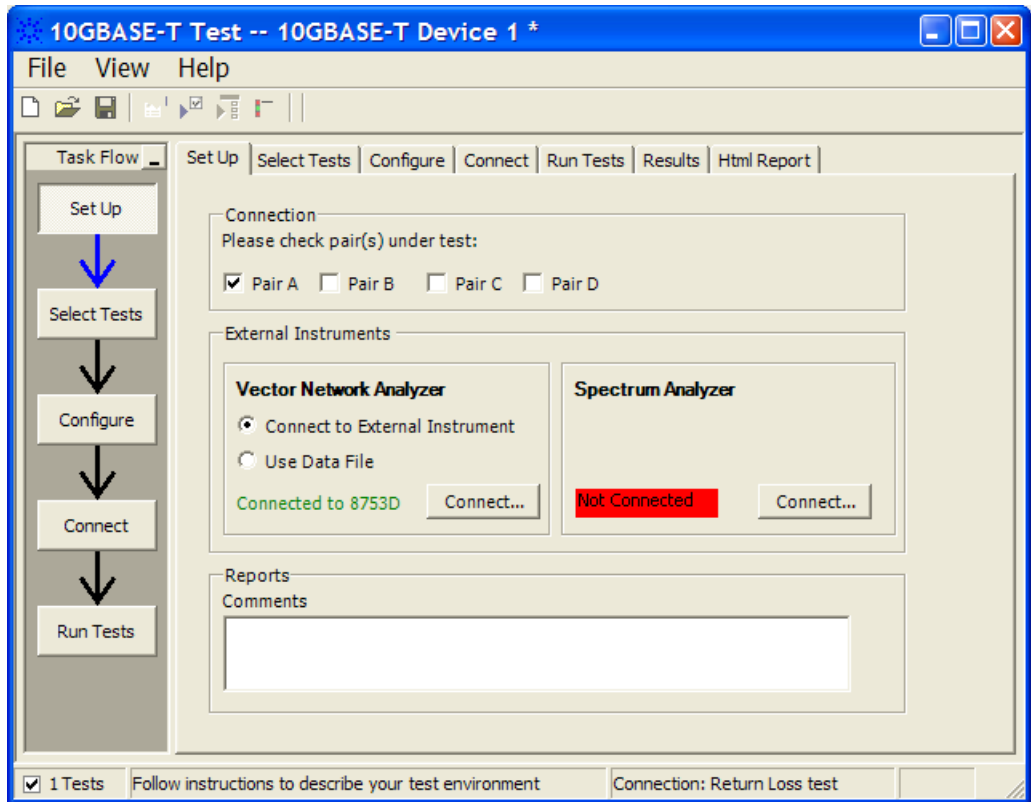

Figure 30 Setup page after application has detected the vector network analyzer

- 10 Instead of connecting to the vector network analyzer, you can also use the data file.
- 11 To do so, click on the Use Data File and the Edit button will appear, as shown in [Figure 31](#). Click on this button to select the data file for each pair.
- 12 A pop-up box will appear where you can browse the data file and assign it to each pair under test, as shown in [Figure 32](#). Select the data file and click OK.
- 13 Once the application detects the user file, it is indicated on the Setup page as shown in [Figure 33](#) below.

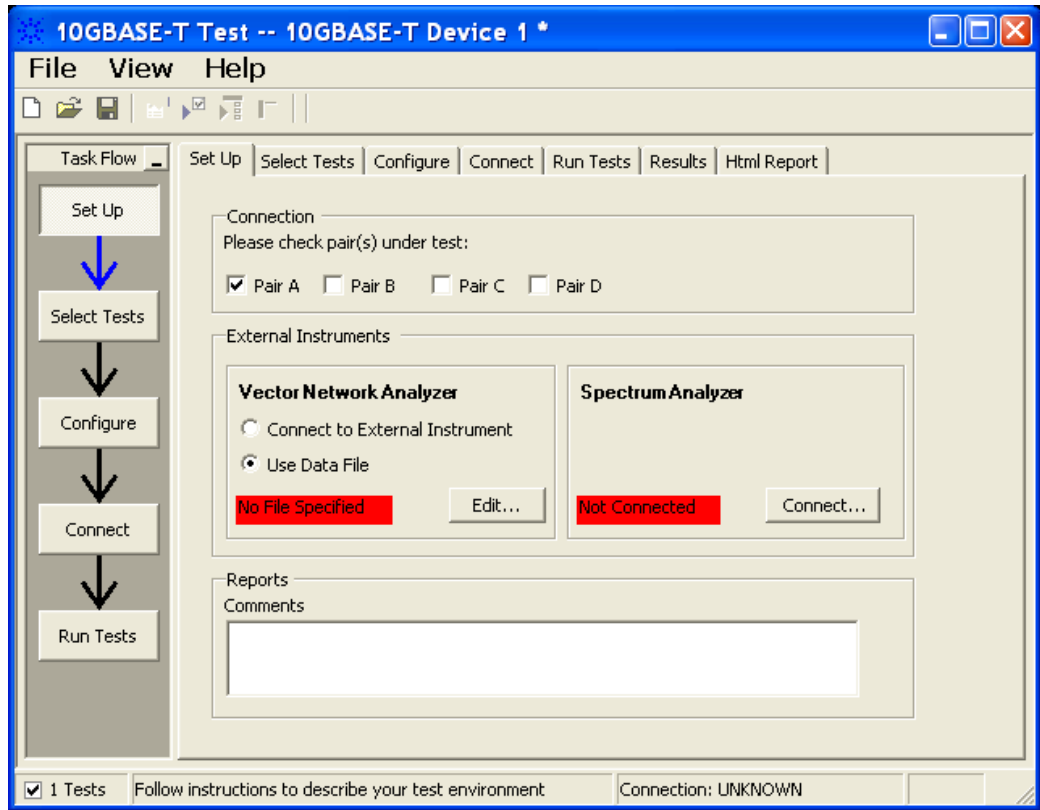

Figure 31 Use data file option for vector network analyzer

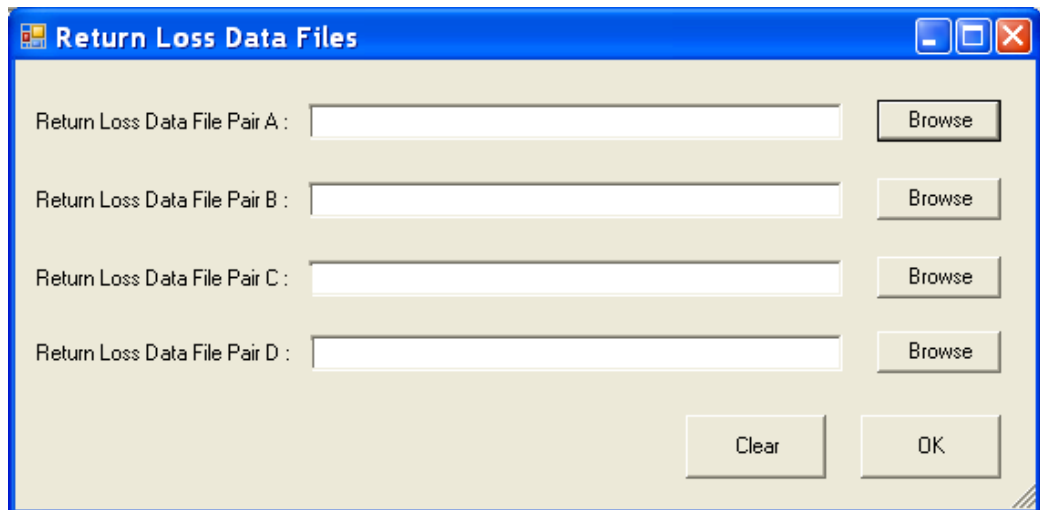

Figure 32 Data file selection pop-up box

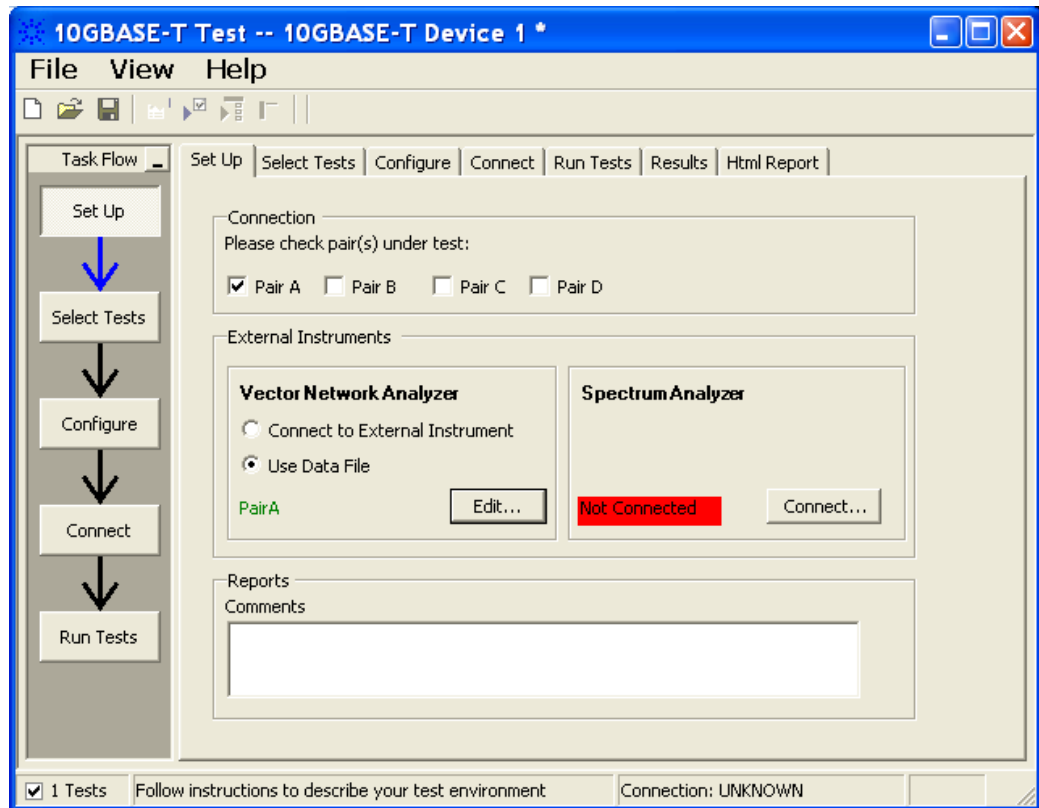

Figure 33 Setup page after application has detected the data file

- 14 Enter your comments in the Comments text box.
- 15 Click the Select Tests tab and check the tests you want to run. Check the parent node or group to check all the available tests within the group.

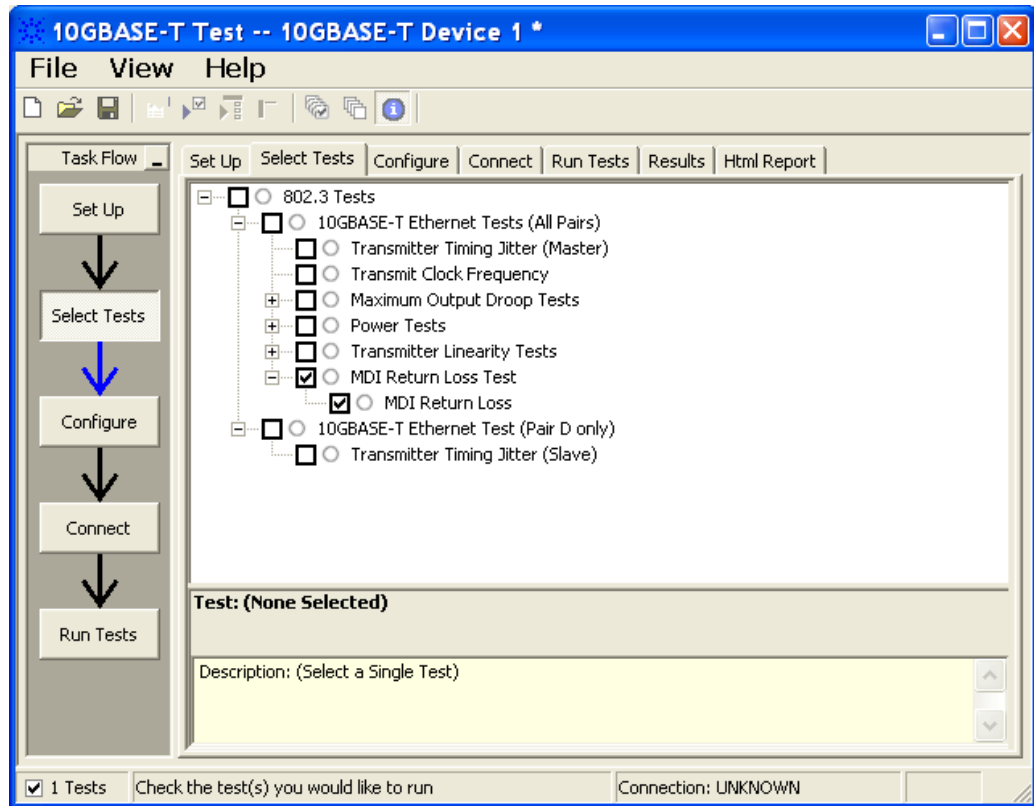

Figure 34 Selecting MDI Return Loss Test

- 16 Follow the 10GEthernet test application's task flow to set up the configuration options (see [Table 8](#)), run the test.
- 17 Before running the test, the application will prompt you to calibrate the test setup. Connect the other end of RJ45 cable to Section 3 of the test fixture to calibrate the test setup. Test setup refers to the setup from the RJ45 cable connection point at Section 3 test fixture to the point where SMA cables are connected to the connector pairs.
- 18 A pop up message box will prompt you to connect the cal fixture to OPEN, SHORT, and LOAD port respectively. When this message is prompt, connect the mentioned port of Section 3 to another end of the RJ45 cable and click OK.
- 19 Once the calibration is done, the application will continue to run the tests.

Table 8 Test Configuration Options

Configuration Option	Description
Connection Pair (Positive)	The channel number for connection pair positive.
Connection Pair (Negative)	The channel number for connection pair negative.

MDI Return Loss Test - Test Method of Implementation

The purpose of the MDI Return Loss test is to verify that the MDI return loss of the device under test (DUT) meets the specified eye template requirement as specified in clause 55.8.2.1 of *IEEE 802.3*.

MDI Return loss of the DUT is verified for each of the four lanes of the test mode 5 signaling for that particular DUT. These pairs are identified as Pair A, Pair B, Pair C and Pair D.

Test Definition Notes from the Specification

Section 55.8.2.1 MDI Return Loss

The differential impedance at the MDI for each transmitter/receive channel shall be such that any reflection due to differential signals incident upon the MDI from a balanced cabling having a nominal differential characteristic impedance of 100 Ω is attenuated, relative to the incident signal as per the relationship:

$$\text{Return loss} \geq \begin{cases} 16 & 1 \leq f \leq 40 \\ 16 - 10\log_{10}(f/40) & 40 \leq f \leq 400 \\ 6 - 30\log_{10}(f/400) & 400 \leq f \leq 500 \end{cases} \quad (55-54)$$

where f is in MHz.

Pass Condition

The return loss obtained must be less than 16 dB from 1 MHz to 40 MHz, at least $16 - 10\log_{10}(f/40)$ from 40 MHz to 400 MHz and at least $6 - 30\log_{10}(f/400)$ from 400 MHz to 500 MHz.

Measurement Algorithm

- 1 Configure the DUT to produce test mode 5 signal.
- 2 Calibrate the vector network analyzer with the calibration fixture (load, open and short).
- 3 Set the vector network analyzer as the following:
 - Start frequency = 1 MHz and Stop frequency = 500 MHz
 - Averaging on.
- 4 Collect the data from the vector network analyzer to the application and plot the graph.

- 5 Analyze the collected data by using Matlab and compute the return loss for the Z_s of 100Ω .
- 6 Compare the test result with the compliance test limit.

Test References

See Section 55.8.2.1 MDI Return Loss in the *IEEE 802.3-2006 Standard*.

10 MDI Return Loss Test

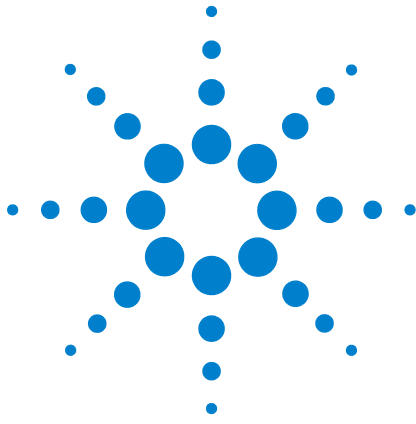

11 Transmitter Timing Jitter (SLAVE) Test

Connection for Transmitter Timing Jitter (SLAVE) Test 86

Transmitter Timing Jitter (SLAVE) Test - Test Method of
Implementation 89

This section provides the Methods of Implementation (MOIs) for Transmitter Timing Jitter (SLAVE) test using an Agilent 80000 or 90000 Series Infiniium oscilloscope, 10GBASE-T Transmitter test fixture and the 10GBASE-T Electrical Conformance Test Application.



Connection for Transmitter Timing Jitter (SLAVE) Test

When performing the Transmitter Timing Jitter (SLAVE) test, the 10GBASE-T Electrical Conformance Test Application will prompt you to make proper connections. The connections for the Transmitter Timing Jitter (SLAVE) test may look similar to the following diagram. Refer to the Connection tab in 10GBASE-T Electrical Conformance Test Application for more details.

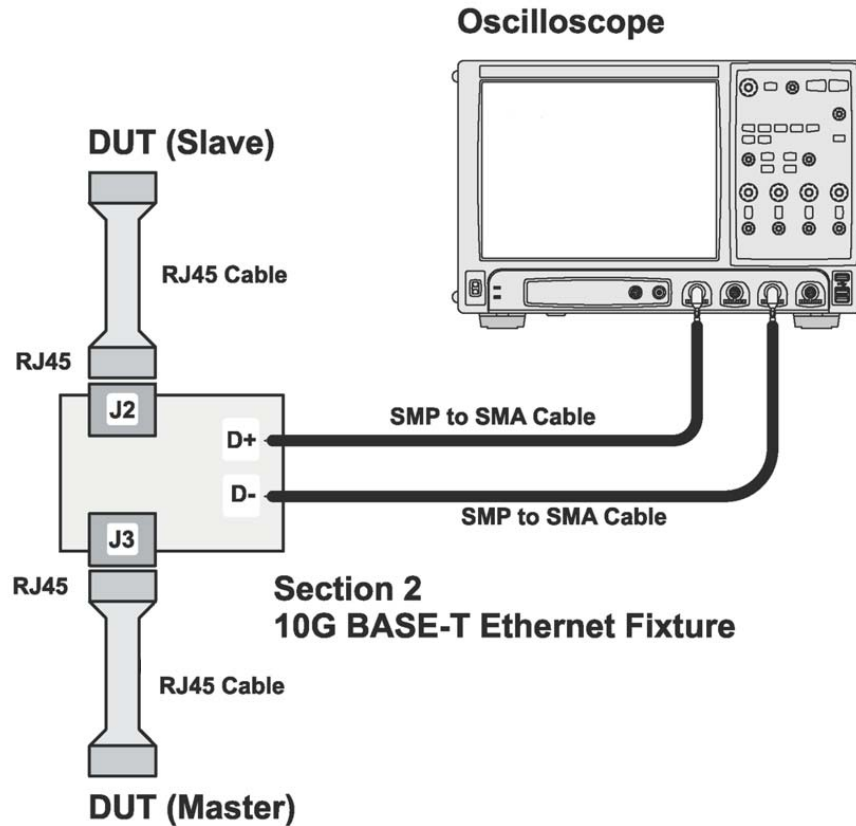

Figure 35 Connection for Transmitter Timing Jitter (SLAVE) Test

You may connect the SMP to SMA cables to any of the oscilloscope channels. You can identify the channels used for each signal in the Configuration tab of the 10GBASE-T Electrical Conformance Test Application. (The channels shown in [Figure 35](#) is just an example.)

Test Procedure

- 1 Start the automated test application as described in “Starting the 10GBASE-T Electrical Conformance Test Application” on page 15.
- 2 Connect one end of the RJ45 cable to the SLAVE DUT and another end to the J2 connector on the Section 2 of the 10GBASE-T Transmitter test fixture.
- 3 Similarly, connect one end of the RJ45 cable to the MASTER DUT and another end to the J3 connector on the Section 2 of the 10GBASE-T Transmitter test fixture.
- 4 Connect the D+ and D- SMP connectors to the any two of the oscilloscope channels by using the SMP to SMA cables.
- 5 In the 10G Ethernet test application, click the Set Up tab.
- 6 Under the Connection group, check the connection pair(s) under test. You can select more than one pair of connection.
- 7 Enter your comments in the Comments text box.
- 8 Click the Select Tests tab and check the tests you want to run. Check the parent node or group to check all the available tests within the group.

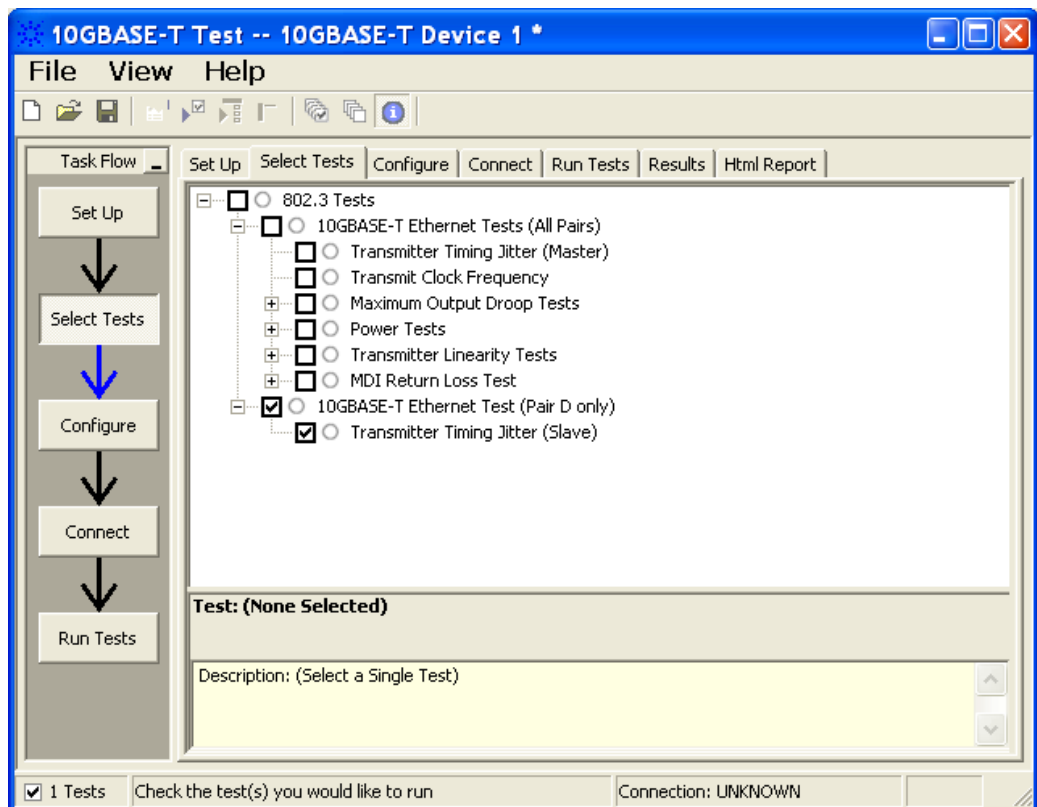

Figure 36 Selecting Transmitter Timing Jitter (SLAVE) Test

11 Transmitter Timing Jitter (SLAVE) Test

- 9 Follow the 10G Ethernet test application's task flow to set up the configuration options (see [Table 9](#)), run the test, and view the test results.

Table 9 Test Configuration Options

Configuration Option	Description
Connection Pair (Positive)	The channel number for connection pair positive.
Connection Pair (Negative)	The channel number for connection pair negative.

Transmitter Timing Jitter (SLAVE) Test - Test Method of Implementation

The purpose of the Transmitter Timing Jitter (SLAVE) test is to verify that the SLAVE transmitter timing jitter of the device under test (DUT) is within the conformance limits specified in clause 55.5.3.3 of *IEEE 802.3*.

For this test, the obtained timing jitter must be less than or equal to 5.5ps over a sample size of 200000 ± 20000. The jitter value is to be verified for Pair D only where the MASTER PHY is set to test mode 1 and SLAVE PHY is set in test mode 3.

Test Definition Notes from the Specification

Clause 55.5.3.3 Transmitter Timing Jitter

RMS period jitter over an integration time interval of 1 ms ± 10% is defined as the root mean square period difference from the average period ($T - T_{avg}$) accumulated over a sample size of 200000 ± 20000.

$$RMS \text{ period jitter} = \sqrt{\frac{\sum [(T - T_{avg})^2]}{\text{Sample Size}}}$$

Pass Condition

The RMS period jitter measured at the MDI must be less than or equal to 5.5 ps for all the pairs.

Measurement Algorithm

- 1 Configure the SLAVE DUT to produce test mode 3 and the MASTER DUT to produce test mode 1 signal.
- 2 Convert the single ended signal to differential signal:
 $\text{FUNC2} = \text{D+ (default Channel1)} - \text{D- (default Channel3)}$ to get the differential signal.
- 3 Trigger on the rising edge of D+. Set the trigger level to offset voltage of D+.
- 4 Set the sampling rate to 20 Gsa/s.
- 5 The number of acquisitions to be taken depends on the time range and the memory depth selected by the customers:
 $\text{Number of Acq} = \text{Time Range} / (\text{Memory Depth} * 1/\text{Sampling Rate})$
- 6 Apply the band pass filter with the parameter as shown below to the signal:

11 Transmitter Timing Jitter (SLAVE) Test

- Center Frequency = 200 MHz
 - Bandwidth = 2 MHz
- 7 Enable the histogram and measure the period to the output of the band pass filter.
 - 8 Take the standard deviation from the histogram statistics.
 - 9 Compare the test result with the compliance test limit.

Test References

See Clause 55.5.3.3 Transmitter Timing Jitter in the *IEEE 802.3-2006 Standard*.



Calibrating the 80000 and 90000 Series Infiniium Oscilloscopes

To Run the Self Calibration 91

Self Calibration 92

This section describes the Agilent 80000 and 90000 Series Infiniium oscilloscopes calibration procedures.

To Run the Self Calibration

NOTE

Let the Oscilloscope Warm Up Before Adjusting. Warm up the oscilloscope for 30 minutes before starting calibration procedure. Failure to allow warm up may result in inaccurate calibration.

The self calibration uses signals generated in the oscilloscope to calibrate channel sensitivity, offsets, and trigger parameters. You should run the self calibration

- yearly, or according to your periodic needs,
- when you replace the acquisition assembly or acquisition hybrids,
- when you replace the hard drive or any other assembly,
- when the oscilloscope's operating temperature (after the 30 minute warm-up period) is more than ± 5 °C different from that of the last calibration.

To calibrate the Infiniium oscilloscope in preparation for running the 10GBASE-T automated tests, you need the following equipment:

Table 10 Equipment Required

Equipment	Critical Specifications	Agilent Part Number
Adapters (2 supplied with oscilloscope except for the DSO90254A)	3.5 mm (f) to precision BNC No substitute	Agilent 54855-67604



Table 10 Equipment Required

Equipment	Critical Specifications	Agilent Part Number
Cable Assembly	50 Ω characteristic impedance BNC (m) connectors ~ 36 inches (91 cm) to 48 inches (122 cm) long	Agilent 8120-1840
Cable Assembly (supplied with oscilloscope except for the DS090254A which can use a good quality BNC cable)	No substitute	Agilent 54855-61620
10 MHz Signal Source (required for time scale calibration)	Frequency accuracy better than 0.4 ppm	Agilent 53131A with Opt. 010

Self Calibration

NOTE

Calibration time: It will take approximately 1 hour to run the self calibration on the oscilloscope, including the time required to change cables from channel to channel.

1 Let the Oscilloscope Warm Up Before Running the Self Calibration.

The self calibration should only be done after the oscilloscope has run for 30 minutes at ambient temperature with the cover installed. Calibration of an oscilloscope that has not warmed up may result in an inaccurate calibration.

2 Pull down the Utilities menu and Select Calibration.

3 Click the check box to clear the Cal Memory Protect condition.

You cannot run self calibration if this box is checked. See [Figure 37](#).

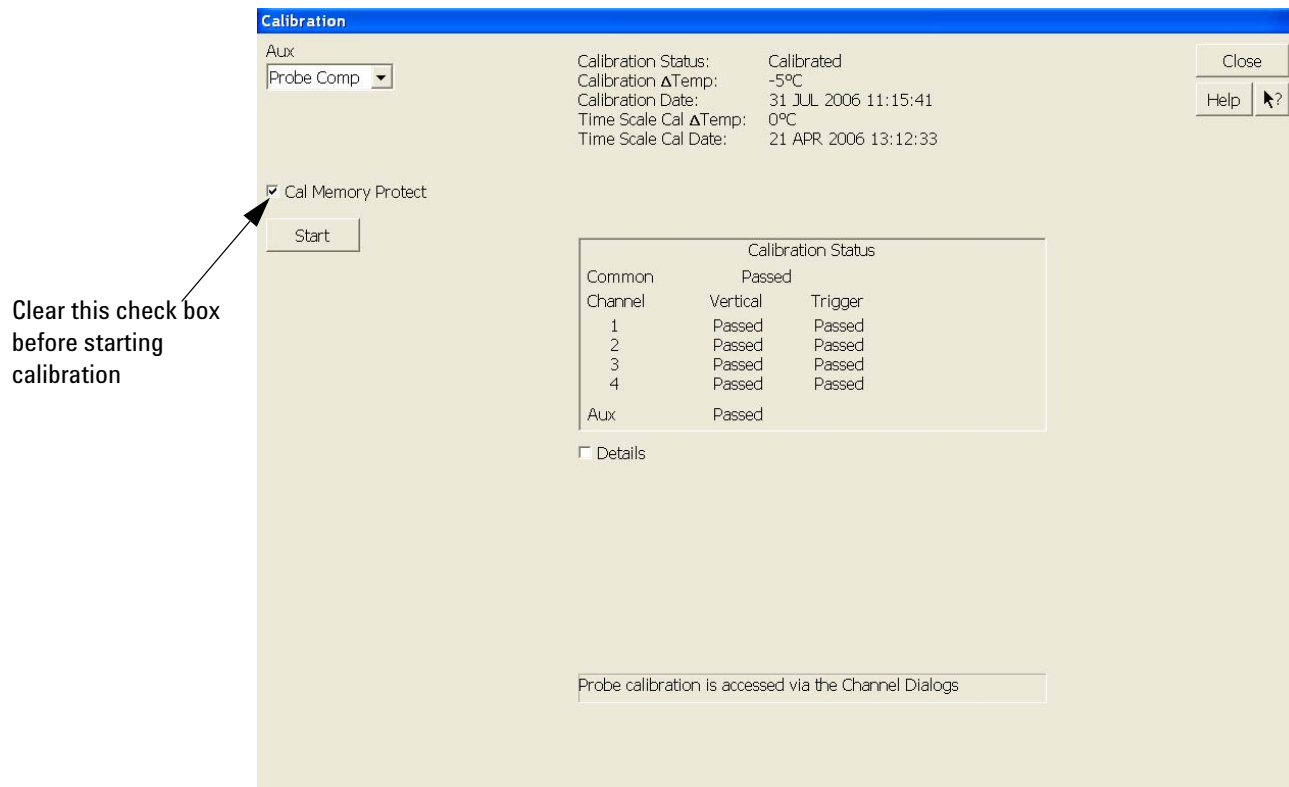

Figure 37 Oscilloscope Calibration Window

- 4 Click Start, then follow the instructions on the screen.

The routine will ask you to do the following things in sequence:

- a Decide if you want to perform the Time Scale Calibration. Your choices are:
- Standard Calibration - Time scale calibration will not be performed. Time scale calibration factors from the previous time scale calibration will be used and the 10 MHz reference signal will not be required. The remaining calibration procedure will continue.
 - Standard Calibration and Time Scale Calibration - Performs the time scale calibration. This option requires you to connect a 10 MHz reference signal to channel 1 that meets the following specifications. Failure to use a reference signal that meets this specification will result in an inaccurate calibration.
 Frequency: 10 MHz \pm 0.4 ppm = 10 MHz \pm 4 Hz
 Amplitude: 0.2 V_{peak-to-peak} to 5.0 V_{peak-to-peak}
 Wave shape: Sine or Square

- Standard Calibration and Reset Time Scale Calibration - Factory time scale calibration factors will be used. The 10 MHz reference signal will not be required. The remaining calibration procedure will continue.
- b** Disconnect everything from all inputs and Aux Out.
- c** Connect the calibration cable from Aux Out to channel 1.
 - You must use the 54855-61620 cable assembly with two 54855-67604 adapters for all oscilloscopes except for the DSO90254A which can use a good quality BNC cable. Failure to use the appropriate calibration cable will result in an inaccurate calibration.
- d** Connect the calibration cable from Aux Out to each of the channel inputs as requested.
- e** Connect the 50 Ω BNC cable from the Aux Out to the Aux Trig on the front panel of the oscilloscope.
- f** A Passed/Failed indication is displayed for each calibration section. If any section fails, check the calibration cables and run the oscilloscope Self Test in the Utilities menu.
- g** After the calibration procedure is completed, click Close.

Index

Numerics

10GBASE-T electrical conformance test application—at a glance, [3](#)

C

calibrating the oscilloscope, [91](#)
configure, [16](#)
connect, [16](#)

H

HTML report, [16](#)

I

in this book, [5](#)

L

license key, installing, [11](#)

M

Maximum Output Droop tests, [37](#)
MDI Return Loss tests, [73](#)

P

Power Level tests, [53](#)

R

report, [16](#)
results, [16](#)
run tests, [16](#)

S

select tests, [16](#)
Starting the 10GBASE-T Electrical Conformance Test Application, [15](#)

T

Transmit Clock Frequency tests, [33](#)
Transmitter Linearity tests, [63](#)
Transmitter Power Spectral Density tests, [43](#)
Transmitter Timing Jitter tests, [27](#), [85](#)

U

U7236A 10GBASE-T PMA Electrical Conformance Test Application, [3](#)

www.agilent.com

© Agilent Technologies, Inc. 2008

Printed in USA
First edition, October 2008



U7236-97000